

robot coupe®



HONG KONG
CATALOGUE
04/2026

FOOD
PROCESSORS

DISCS

VEG PREP
MACHINES

CUTTER
MIXERS

ROBOT COOK®

BLIXER®

IMMERSION
BLENDERS

JUICE
EXTRACTORS

PLANETARY
MIXER

robot  coupe[®]

**CALL YOUR LOCAL TERRITORY MANAGER TO ARRANGE
A FREE, NO OBLIGATION DEMONSTRATION IN YOUR KITCHEN**

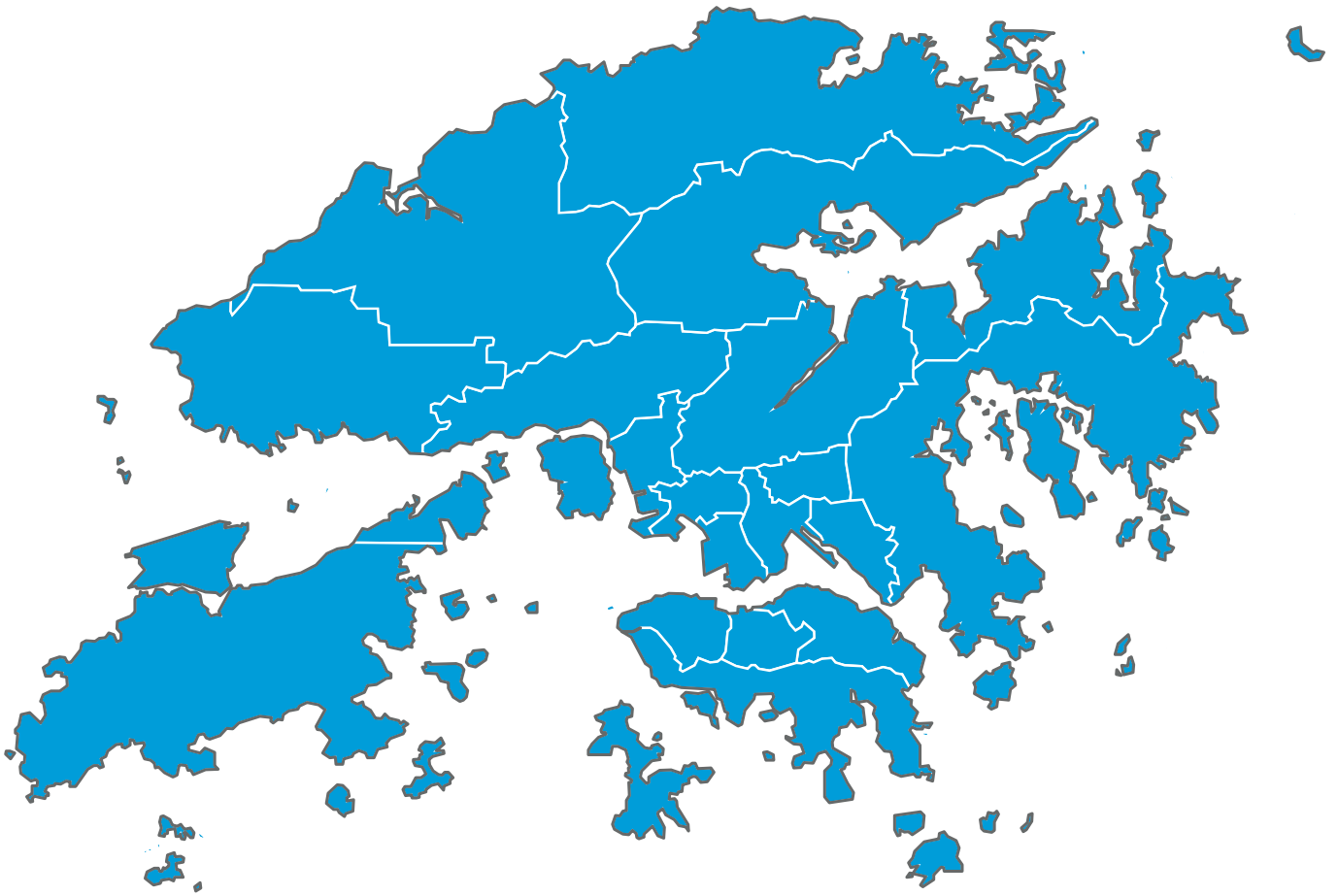

Hong Kong / Macao
Tel : (+852) 54996452

NEW PRODUCTS AND FEATURES

robot coupe®

PAGE **168**

PLANETARY MIXER

Discover the new Planetary Mixer, equipped with a powerful, silent motor, for your everyday cooking and pastry preparations.



PAGE **76**



CL 60

New built-in ejection guide

- Guides vegetables out of the bowl.
- Designed for optimal distribution of the ingredients in the GN container.

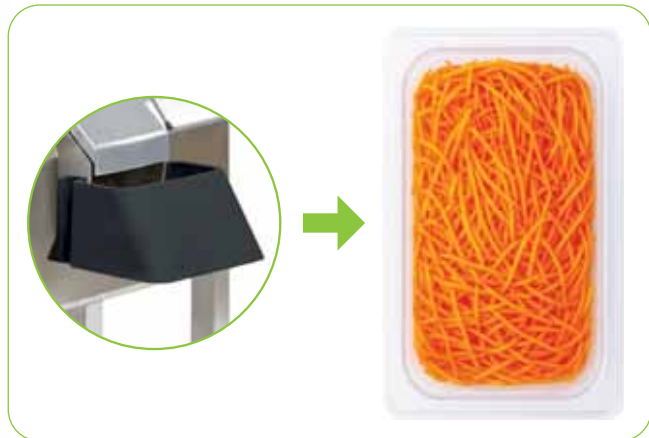

PAGE **36**

THE SOLUTION FOR A PERFECT RIPPLE CUT

Boost your creativity with two new disc sizes!



robot coupe®

INNOVATION AT THE HEART OF OUR HISTORY

Since 1961, Robot-Coupe has designed, developed and manufactured all its products in France, the home of gastronomy.



MORE THAN 60 YEARS OF INNOVATION

HUNDREDS OF EXCLUSIVE PATENTS

1961: 1st standing vegetable slicer
1966: 1st Vertical Cutter Mixer

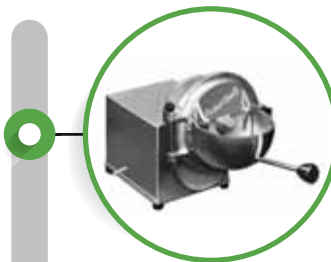

1960 / 1970

1970 / 1980



1970: 1st Food Processor
1975: Ranges of Cutter Mixers and Food Processors

1980: 1st Blixer® - Blender Mixer
1986: 1st CL 50 Vegetable Preparation machine



1990 / 2000



1990: Range of Vegetable Preparation machines
1996: 1st Immersion Blender with removable foot

2000: Range of Immersion Blender
2008: 1st Automatic Juice Extractor
2012: The 1st Professional Cooking Cutter Blender



2020: Launch of new Juice Extractor range and
13 new large-capacity table-top models of
Food Processors, Cutter Mixers and Blixer®.
2024 : EasyStacker
EasyLoader

2026: Launch of new Planetary Mixer



All the latest Robot-Coupe® innovations are indicated with the  pictogram.

robot coupe®

WORLD LEADER PRESENT IN MORE THAN 130 COUNTRIES



LOCAL COMMITMENT FOR OVER 40 YEARS

Present in more than 130 countries, Robot-Coupe uses its expertise and know how as a world leader to constantly adapt to different types of local cuisine. Across the globe, our teams provide ongoing support to distributors and catering professionals to meet their specific needs.



A CULTURE OF COMMITMENT



DESIGNED AND MADE IN FRANCE

Robot-Coupe products are all designed and made in France to guarantee a superior level of quality and ensure unbeatable performance. Our products are always at the cutting edge of technology and excellence.

INNOVATIVE AND DURABLE

Because our goal is to meet your needs, innovation is our focus to anticipate your every requirement.

We commit to offering you high performance, durable products that exceed the current norms, with technical and industrial choices designed to guarantee the durability, maintenance and reparability of our products.



INSPIRING AND SATISFYING

Being your partner in the kitchen stimulates our research and development to imagine, improve and create new ways of utilising our products.

Your satisfaction is our priority to build a lasting relationship of trust and allow you to express your full culinary creativity.

robot coupe®

A COMPANY COMMITTED TO SUSTAINABLE DEVELOPMENT

Throughout the decades, Robot-Coupe has been committed to a policy of social and ethical responsibility with four points of focus.

“ Our **heavy duty** machines
are designed **to last** ”

“ We **go beyond the requirements** to guarantee
the **highest levels**
of performance ”



“ Our **partners are based in Europe**
and we support them in developing
a **sustainable approach** ”

“ **100%** of our machines
can be repaired and **more**
than 95% recyclable ”

STRONG COMMITMENTS THROUGHOUT THE SERVICE LIFE OF PRODUCTS

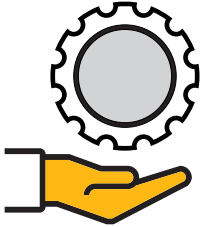

DESIGN

Products designed to last

- The materials used for our machines are high quality and long lasting.
- Our machines provide energy efficiency and savings throughout their service life.
- 100% of our products can be repaired.
- Spare parts are available for more than 10 years after a product is discontinued.

PRODUCTION

Ethical and responsible practice

- Compliance with the most stringent standards.
- Application of the ROHS directive (Restriction Of Hazardous Substances) and incorporation of future standards such as the EuP (Energy Using Product).
- The choice of European supply partners to reduce transport and its impact on the environment.

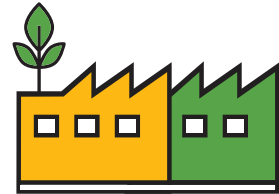

RESOURCES

Sustainable resource management:

- Reduction in packaging from design onwards and decrease in production waste.
- High precision machines to reduce waste in the kitchen.
- Our products are more than 95% recyclable.
- Participation in waste collection and recycling schemes in each country.



PEOPLE

A socially committed company:

- An individual employee development policy and promotion of ethics.
- Respect of International Labour Organisation standards.
- Sharing of our CSR requirements with our partners with corresponding support and backing.



robot coupe®

AT YOUR SERVICE



BY YOUR SIDE IN THE FIELD

- Machine demonstrations
- Inspection of existing material
- Technical in-restaurant training
- Support for machine repairs, maintenance and spare parts
- Sharing of experience.



REQUEST A DEMO

TO IMPROVE USERS' DAILY LIFE

Machine QR code to access full product information on robot-coupe.com: videos, manuals, documentation, maintenance, accessories, safety information...



Easy Guide



A TRUSTED PARTNER



CUSTOMER SERVICE TO ASSIST YOU

- A dedicated team answers questions about your order, quotation, invoice or shipping
- Delivery of products and accessories within 48 hours / Spare parts within 24 hours

HIGH-PERFORMANCE LOGISTICS CENTRE

- Warehouse with 90% of our references in stock
- A dedicated team tracks and organises orders and ensures shipment traceability

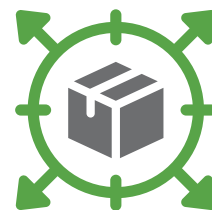

HIGH-TECH ASSISTANCE

- Dedicated team
- Help with trouble-shooting, repairs, maintenance
- Video tutorials

EFFICIENT AFTER-SALES SERVICE

- After-sales service website where you can:
 - Consult exploded views and wiring diagrams of spare parts
 - Search for references & prices
 - Place orders in real time



robot coupe®

EASY LIFE



FOR A PERFECTLY EVEN & PRECISE CUT

Vegetable Preparation Machines - Food Processors



Exactitube
To cut small ingredients into regular slices



EasyLoader
To continuously make long and perfectly formed French fries



EasyStacker
For perfectly sliced and stacked tomatoes



REDUCE STRAIN → PREVENT MUSCULOSKELETAL DISORDERS

Immersion Blenders - Juice Extractors



EASY TO REPAIR

Immersion Blenders



EasyPlug
Easier replacement of power cord



EasyGrip
Removable handle for better grip

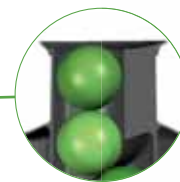

Automatic feed tube
With the exclusive automatic feed system, fruit and vegetables can be processed effortlessly

MAKES LIFE EASIER

EASY CLEANING



BLADES



Removable stainless steel blades



Dishwasher-safe blades

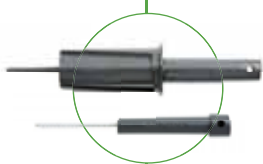

Blade-cleaning tools



EasyBell
Immersion Blenders
Removable bell and blades



DISCS



Discs Mineral+
Easy to clean in dishwasher



D-Clean Kit
Dicing grid cleaning tool



EasyClean XPress
Zero-waste solution to clean dicing grids



robot coupe®

IS AT YOUR SIDE



MINI CATALOGUE

MINI CATALOGUE

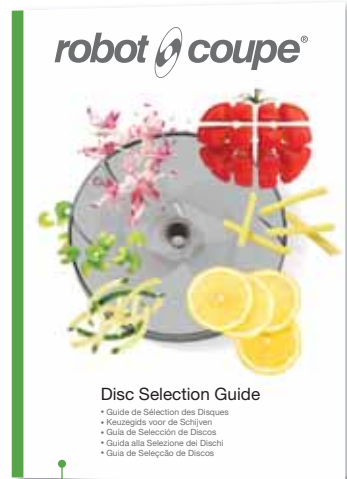

Disc Selection Guide

- Guide de Sélection des Disques
- Keuzegids voor de Schijven
- Guía de Selección de Discos
- Guida alla Selezione dei Dischi
- Guia de Selección de Discos

SELECTION GUIDE
Discs

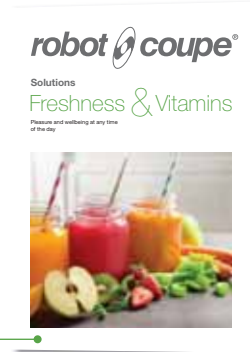

RECIPE BOOKS
Freshness & Vitamins



RECIPE BOOKS
Nutrition & Healthcare



RECIPE BOOKS
Robot Cook

AT TRADE FAIRS IN 2026



IN YOUR STORES AND SHOWROOMS



Set of 3 displays

Ref. 451 581

Dimensions: L126 x H60 x W40 cm



R 301 discs display
Ref. 450 367

CL 50 discs display
Ref. 450 366

3 machines display
Ref. 407 818

Header only: Ref. 430 356

Mixed display stand
Ref. 450 421

Header only: Ref. 450 767

Immersion Blender display stand
Ref. 407 435

Header only: Ref. 430 323

robot coupe®

IS AT YOUR SIDE

FIND ALL OUR VIDEOS ON THE OFFICIAL ROBOT-COUPÉ CHANNEL:



Robot-Coupe R 301 Ultra video



Robot-Coupe CL 50 Ultra video



Robot-Coupe J 100 video

VIDEOS ALSO ON
robot-coupe.com

ON THE OFFICIAL ROBOT-COUPÉ SOCIAL MEDIA



LinkedIn
robot-coupe-official



Facebook
RobotCoupeOfficial



Youtube
Robot-Coupe Official



Instagram
robotcoupe_official

AND WITH OUR AFTER SALES SERVICE

FIND MY MACHINE ORDER

To access information about your machine, you need to enter its serial number or, failing that, the first 3 digits of the number.

Machine serial number

00 30420111001 00 444 **SEARCH**

Where can I find my serial number?

VIDEO TUTORIALS
Help with repair or maintenance

Can't identify your equipment?
You don't have the serial number or you're looking for an accessory? We're here to help! **SEARCH**

VIDEO TUTORIALS

PRODUCTS FAMILY:

- FOOD PROCESSORS
- CLUTTER REMOVER
- FRUIT Slicer
- CHOP
- MP
- AXIS EXTRACTORS

07 Models out of 10 videos

J90.2100 - Shaft pin replacement

Robot Cook - Replacement of Motor upper bearing with flange

ICM - Arm safety switch setting

MP - Circuit board change

Online support

To report non compliant orders , transport damage, or to request technical assistance.

After Sales Service videos

To train your technicians on maintenance and repair operations.

A COMPREHENSIVE WEBSITE



NEW



NEW ROBOT-COUPÉ WEBSITE

- **Responsive design and user friendly:** easy access to information no matter your device (desktop computer, mobile, tablet)
- **Videos:** discover our products live and train yourself

FOR YOU, DEALERS AND KITCHEN PLANNERS



- **Dedicated access:** consult and download technical instructions, specifications, 2D, 3D & BIM drawings

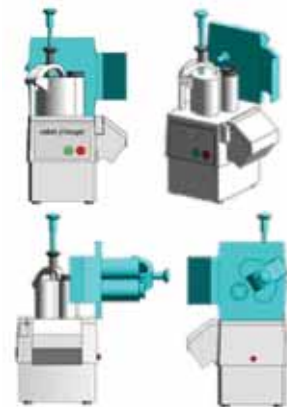

FOR YOUR CUSTOMERS

- **Selection guide:** find the right machine in just a few clicks
- **Product registration:** download user' manuals and safety instructions sheets

robot coupe[®]

SOLUTIONS FOR EVERY FOOD SECTOR

COMMERCIAL FOODSERVICE



FAST FOOD

- Fast Food
- Juice Bars
- Takeaway
- Salad & Sandwich Bars
- Cafeterias
- Food Courts



CONTRACT CATERING



CATERING FOR THE EDUCATIONAL SECTOR

- Day care
- Pre-school
- Primary school
- High school
- University
- Central kitchens



ARTISANS AND SUPERMARKETS



BAKERS AND CONFECTIONERS

- Bakers
- Confectioners
- Tea rooms
- Ice cream parlours
- Chocolate makers
- Pie shops



COMMERCIAL FOODSERVICE

FULL SERVICE

Casual dining
Traditional restaurants
Theme restaurants
Chains
Bistro cuisine
Gourmet cuisine

HOTEL CATERING

All categories of hotels
Banquets
Holiday centres
Camping grounds
Staff canteens



SOCIAL FOOD SERVICE

Company restaurants
Institutional restaurants
Mining Sites
Army
Prisons
Central kitchens

CATERING IN THE HEALTHCARE SECTOR

Retirement / Nursing Homes
Hospitals
Special needs facilities
Central kitchens



CONTRACT CATERING

DELICATESSEN CATERING

Delicatessens
Caterers

SUPERMARKETS

Freshly cut food
Greengrocers
Juice bars
Delicatessens
Snack bars
Food Courts



#THEsolution

robot



MAKE LIFE EASIER FOR THE USER

Fewer manual tasks to take away the strain



SAVE TIME

Increase productivity

ULTRA FRESH JUICE
2L = 1min



HOMEMADE FRENCH FRIES
20kg = 4 mins



CHOPPED VEGETABLE SALAD
10kg = 2mins



SOUP
45L = 6 mins



MAYONNAISE
2L = 1min



COLESLAW
300kg = 1hr



SAVE MONEY

Return on investment in less than 6 months!

Examples:



Invest in a CL 50
= Save one hour of work a day.



Invest in a Robot Cook®
= Save 20 minutes per service.



DECREASE WASTE



BOOST YOUR CREATIVITY

Let your imagination run wild



SATISFY YOUR CUSTOMERS



FRESHNESS AND ORIGINS OF PRODUCT



HOMEMADE



LOCAL



SEASONAL PRODUCT

PAGE **50**

VEGETABLE PREPARATION MACHINES

CL 50 Ultra



PAGE **84**

Blixer®
Blixer® 4 V.V.



PAGE **114**

JUICE EXTRACTORS

J 80



CONTENTS

FOOD PROCESSORS

PAGE 22

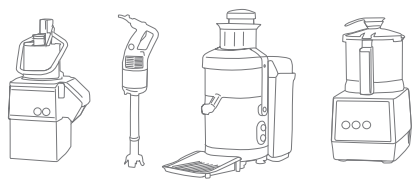

DISC COLLECTION

PAGE 34

VEGETABLE PREPARATION MACHINES

PAGE 48

CUTTER MIXERS

PAGE 64

ROBOT COOK®

PAGE 78

BLIXER®

PAGE 82

IMMERSION BLENDERS

PAGE 92

JUICE EXTRACTORS

PAGE 110

TECHNICAL DATA

(dimensions, weight, etc) PAGE 120

PLANETARY MIXER

PAGE 116

FOOD PROCESSORS

CUTTER MIXERS & VEGETABLE SLICERS



2 MACHINES IN ONE!

Space saving and multifunctional, the Robot-Coupe Food Processor is one of the Chef's greatest allies even in a very small kitchen.

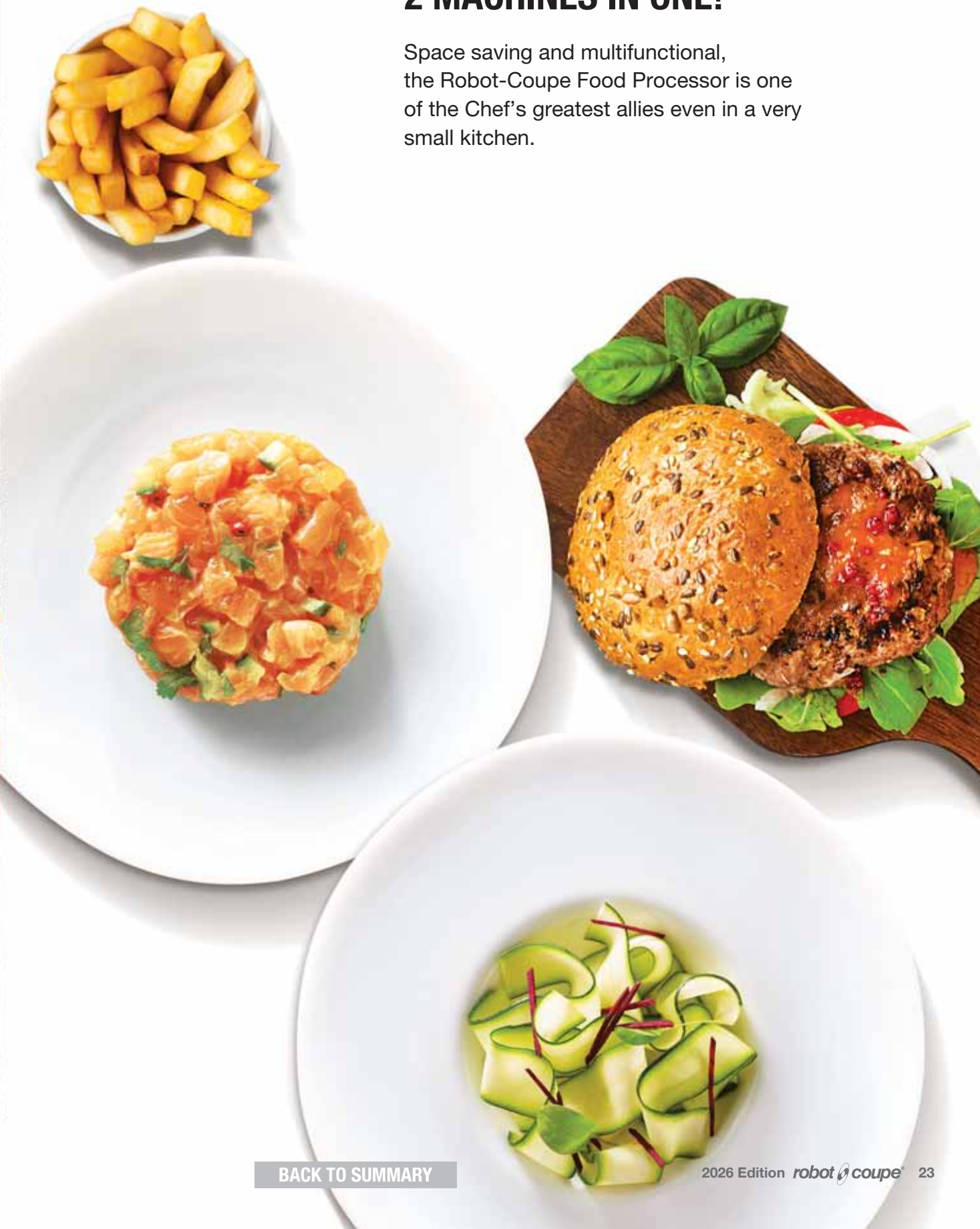

FOOD PROCESSORS

CUTTER MIXERS & VEGETABLE SLICERS



4 MACHINES in 1!

Automatic push button restart: faster and more convenient to operate.

Large Hopper: large vegetables



Cylindrical hopper with Exactitube pusher:

- Ø58mm: long vegetables
- Ø39mm: small caliber ingredients

Lid: Designed so that liquids and other ingredients can be added during processing.

Handle: Ergonomic to make it easy to grasp the bowl.

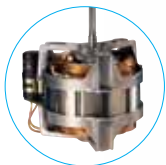

INDUCTION MOTOR

Easy Guide

Variable speed: 300 to 3 500 rpm for a greater variety of applications.



Bowl-base twin-blade assembly
To process both large and small quantities. Coarse and fine serrated blade available as options.



Range of 29 discs available as options.



Lateral ejection: Space saving and ergonomic.



Dishwasher safe



BOOST PRODUCTIVITY

Cutter

1.5 kg = 2 min*

Meatballs



Veg. Prep.

10 kg = 2 min*

Diced tomatoes



*The data may vary depending on the cuts and ingredients

CUTTER FUNCTION



Smooth blade
Supplied as standard



COARSE CHOPPING



FINE CHOPPING



SAUCES, EMULSIONS



Coarse serrated blade

Designed for grinding & kneading



KNEADING



GRINDING



Fine serrated blade

Designed for herbs & spices



CHOPPING HERBS



GRINDING SPICES

VEGETABLE PREPARATION FUNCTION



SLICING



JULIENNE



NEW



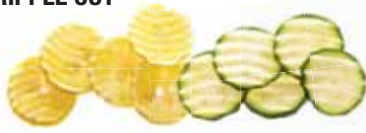

RIPPLE CUT





Mineral+ + DICING*





Mineral+ + FRENCH FRIES*



* For R 402 V.V., R 502 V.V., R 752 V.V.

Juice and Coulis Extraction Function*

- Extraction of fruit and vegetable juices for appetizers, sauces, sorbets, ice cream, smoothies, jam, fruit jellies, etc.
- Coulis function to extract pulp rich juices from cooked or tender fruit and vegetables.
- Citrus press function for all types of citrus fruits.



* Available for R 301 Ultra & R 402 V.V.



GRATING / SLICING / RIPPLE CUT / JULIENNE



+ DICING + FRENCH FRIES

R 402 V.V.

4.5 L



- Single phase
- Variable speed
- Juice Extractor Kit*

R 301 Ultra

3.7 L



- Single phase
- 1 speed
- Juice and Coulis extractor kit*



GRATING / SLICING / RIPPLE CUT / JULIENNE

+ DICING + FRENCH FRIES

**R 502 V.V.**

5.9 L



- Single phase
- Variable speed
- R-Mix®
- **Potato Ricer Attachment***

R 752 V.V.

7.5 L



- Single phase
- Variable speed
- R-Mix®
- **Potato Ricer Equipment***

***Optional attachment**

R-Mix® : Reverse rotation blending function

Models	Maximum quantity for cutter function	Hourly capacity for vegetable preparation function	Number of covers
R 301 Ultra	1.5 kg	50 kg/hr	1 to 100
R 402 V.V.	2.5 kg	50 kg/hr	1 to 100
R 502 V.V.	3.2 kg	150 kg/hr	50 to 300
R 752 V.V.	3.8 kg	250 kg/hr	200 to 600

Juice and Coulis EXTRACTOR KIT

- Extraction of fruit and vegetable juices for appetizers, sauces, sorbets, ice cream, smoothies, jam, fruit jellies, etc.
- Coulis function to extract pulp rich juices from cooked or tender fruit and vegetables.
- Citrus press function for all types of citrus fruits.
- Replaces numerous manual tools:

COULIS FUNCTION

+

CITRUS PRESS FUNCTION



Large capacity hopper
75 x 90 mm

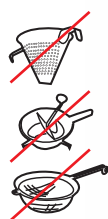

RASPBERRY COULIS
FOR SORBETS



COULIS
FOR APPETIZERS



COCONUT MILK



LEMON JUICE



LEMON TART



ORANGE JUICE



Juice and Coulis extractor kit for R 301 Ultra / R 402 V.V.

Citrus fruit attachment for R 301 Ultra / R 402 V.V.

Ref.
27396
27395



R 301 Ultra

Motor	Induction
Power	650 W
Voltage	Single phase
Speed	1 500 rpm
Pulse	✓
Motor Base	Metal
Cutter	3.7 L stainless steel bowl
Blade	Stainless steel smooth blade - Included
Vegetable slicer	Half moon hopper 1.6 L Cylindrical hopper Ø 58 mm
D-Clean Kit	-
Discs	Not included



R 402 V.V.

Motor	Induction
Power	1 000 W
Voltage	Single phase
Speed	300 to 3 500 rpm for cutter 300 to 1 000 rpm for vegetable slicer
Pulse	✓
Motor Base	Metal
Cutter	4.5 L stainless steel bowl
Blade	Stainless steel smooth blade - Included
Vegetable slicer	Half moon hopper 1.6 L Cylindrical hopper Ø 58 mm and Ø 39 mm, Exactitube pusher - Included Stainless steel bowl
D-Clean Kit	Included
Discs	Not included

Choose your model:



R 301 Ultra	Ref.
R 301 Ultra 230V/50/1 UK plug	2447

R 402 V.V.	Ref.
R 402 V.V. 230V/50/1 UK plug	2478M

Discover our selection of discs and packs on page 38



Choose your options:



	R 301 Ultra		R 402 V.V.	
Options	Ref.		Ref.	
Coarse serrated blade Especially for grinding & kneading	27288		27346	
Fine serrated blade Especially for herbs & spices	27287		27345	
Additional smooth blade	27286		27344	
Cutter accessory (bowl, lid, blade)	27278		27342	
Juice and Coulis extractor kit	27396		27396	
Citrus press attachment	27395		27395	



POTATO RICER

MODELS R 502 V.V., R 752 V.V.



Potato Ricer Attachment



Feed hopper
(R 502 V.V. only)

1

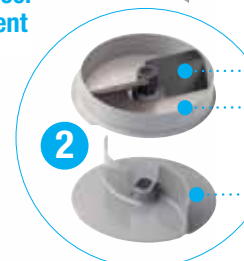

Paddle

Puree grid:
3 mm or 6 mm

Special ejection disc

2

Potato Ricer Equipment

The Potato Ricer Attachment consists of:

- a feed hopper to handle large quantities of potatoes (for R 502 V.V. only)
- a paddle
- a special Ø 3 mm or 6 mm grid
- a special puree ejection disc.



		Ref.
Potato Ricer Attachment Ø 3 mm (R 502 and R 502 V.V.)	1 + 2	28207
Potato Ricer Equipment Ø 3 mm	2	28208
Potato Ricer Attachment Ø 6 mm (R 502 and R 502 V.V.)	1 + 2	28209
Potato Ricer Equipment Ø 6 mm	2	28210



R 502 V.V.

Motor	Induction
Power	1 500 W
Voltage	Single phase
Speed	300 to 3 500 rpm for cutter 300 to 1 000 rpm for vegetable slicer
Pulse	✓
Motor base	Metal
Cutter	5.9 L stainless steel bowl
Scraper arm	✓
Blade	Stainless steel smooth blade - Included Blade cleaning tool - Included
Vegetable slicer	Half moon hopper 2.2 L Cylindrical hopper Ø 58 mm and Ø 39 mm, Exactitube pusher - Included
D-Clean Kit	Included
Discs	Not included

Choose your model:

R 502 V.V.	Ref.
R 502 V.V. 230V/50-60/1 UK plug	2389

Discover our selection of discs and packs on page 38



Choose your options:



R 502 V.V.	
Options	Ref.
Coarse serrated blade Especially for grinding & kneading	27305
Fine serrated blade Especially for herbs & spices	27304
Additional smooth blade	27303
Cutter accessory (bowl, lid, blade)	27320
Blade cleaning tool	49258

R 752 V.V. FOOD PROCESSORS

- Multi-purpose, space-saving and high-performance thanks to their greater processing capacity
- A timer for greater convenience
- New attachments especially designed for professional needs!

Adjustable hopper to suit all size fruit and vegetables!



- Requires less effort
- Prevents MSD
- Takes away the tediousness



Extra large hopper:
Up to 15 tomatoes or
1 whole cabbage.



**Cylindrical hopper
Ø 58 mm:** For
uniform cutting of
long vegetables.



Exactitube pusher:
Cylindrical hopper with Ø 39 mm
Exactitube pusher to cut up small
fruit and vegetables such as chillis,
gherkins, dry sausage, asparagus,
spring onions, bananas,
strawberries, grapes, etc.

INNOVATION

Extra ergonomic:
Lever with assisted
movement = less effort
for the operator.

Timer:
Less effort, greater
precision and more
regular results no matter
what the recipe.

Easy Guide

Motor power:
Ideal for demanding preparations.

Lateral ejection:
Space saving and convenient
to use.

Lid:
Liquids and other ingredients can
be adding during processing.



Scraper arm:
Designed to easily scrape the
lid and edges of the bowl
without stopping the machine.

**7.5 L large capacity bowl
with ergonomic handle:**
Saves time by increasing the
quantities processed.*



**Delivered with all stainless steel
smooth blade:** 2 detachable
adjustable blades.



**Range of more than
50 discs available
as options.**

Options for R 752 V.V.	Ref.
Coarse serrated blade <i>Designed for grinding & kneading</i>	27308
Fine serrated blade <i>Designed for herbs & spices</i>	27307
Additional stainless steel smooth blade	27306
Cutter accessory (bowl, lid, blade)	27318
Lower coarse serrated blade	49162
Upper coarse serrated blade	49163
Lower fine serrated blade	49164
Upper fine serrated blade	49165
Lower smooth blade	49160
Upper smooth blade	49161
3 mm Potato Ricer Equipment	28208
6 mm Potato Ricer Equipment	28210
Motor shaft brush	49257

*5.9 L bowl for R 502 V.V. and 7.5 L for R 752 V.V.



R 752 V.V.

Motor	Induction
Power	1 500 W
Voltage	Single phase
Speed	300 to 3 500 rpm for cutter 300 to 1 000 rpm for vegetable slicer
Pulse	✓
Motor base	Metal
Cutter	7.5 L stainless steel bowl
Scraper arm	✓
Blade	All stainless steel detachable, adjustable smooth blade - Included
Vegetable slicer	Full moon hopper 4.4 L Cylindrical hopper Ø 58 mm and Ø 39 mm, Exactitube pusher - Included
Accessories	Motor shaft brush - Included
D-Clean Kit	Included
Discs	Not included

Choose your model:

R 752 V.V.	Ref.
R 752 V.V. 230V/50-60/1 UK plug	2080

Choose your pack of discs:

							Ref.
Asia Pack of 7 discs							
Slicers 2mm - 5mm	Grater 2mm	Julienne 2x2mm - 3x3mm	Dicing Equipment 10x10x10mm	Wall disc holder			2023W
MultiCut Pack of 16 discs							
Slicers 1mm - 2mm 4mm	Grater 1.5mm 3mm	Julienne 2.5 x 2.5 mm 2 x 10 mm - 4 x 4 mm	Dicing Equipment 5 x 5 x 5 mm - 10 x 10 x 10 mm 20 x 20 x 20 mm	French Fries Equipment 10x10x10 mm	Wall disc holder x2	2022W	

Choose your options opposite:

Discover our selection of discs and packs on page 38



DISC COLLECTION



THE WIDEST RANGE OF CUTS

More than 50 discs to choose from to slice, grate, julienne, dice, chop, shred, waffle cut and cut French fries with perfection in next to no time. Save hours of work each day using Robot-Coupe Food Processors and Vegetable Preparation Machines.

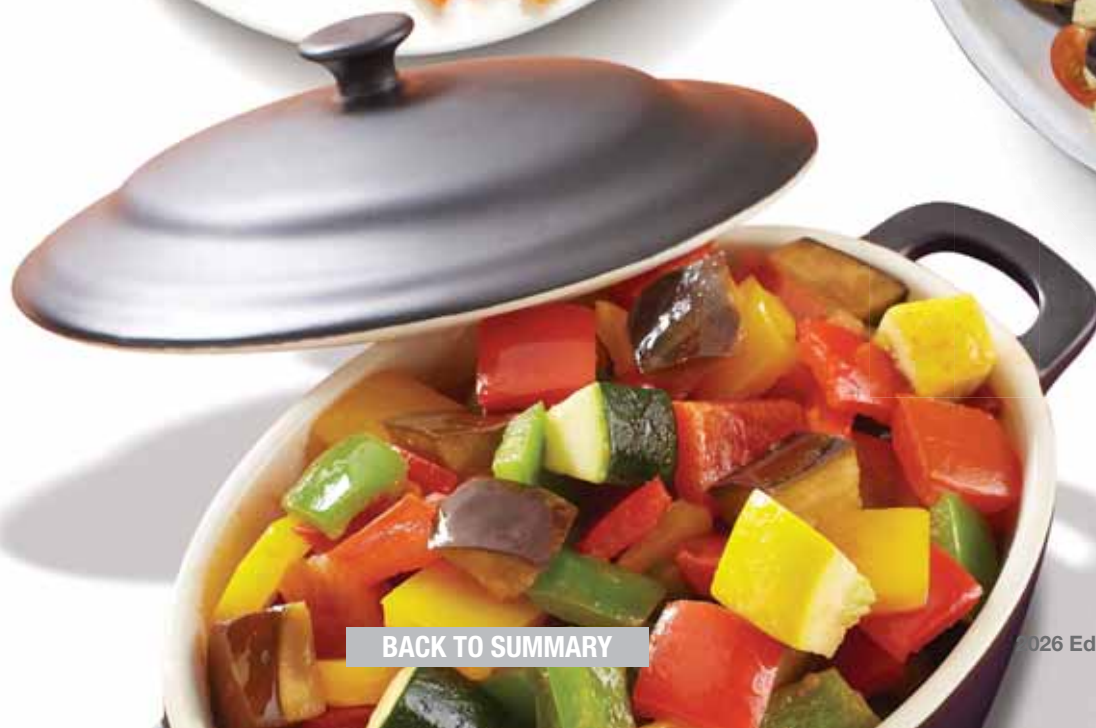

DISC COLLECTION



ESSENTIAL Series 1-4

EXPERT Series 5-7

	R 301 Ultra	R 402 V.V.	DISCS	R 502 V.V. R 752 V.V.
SLICERS				
	27051	27051	Almonds 0.6 mm	28166W
	27555	27555	0.8 mm	28069W
	27086	27086	1 mm	28062W
	27566	27566	2 mm	28063W
	27087	27087	3 mm	28064W
	27786	27786	4 mm	28004W
			5 mm	28065W
		6 mm	28196W	
		8 mm	28066W	
		10 mm	28067W	
		14 mm	28068W	
		4 mm cooked potatoes	27244W	
		6 mm cooked potatoes	27245W	
RIPPLE CUT	NEW 27622	NEW 27622	2 mm	27068W
	27623	27623	3 mm	27069W
GRATERS	27588	27588	5 mm	27070W
	27577	27577	1.5 mm	28056W
	27511	27511	2 mm	28057W
			3 mm	28058W
	27046	27046	4 mm	28073W
			5 mm	28059W
	27632	27632	6 mm	
	27764	27764	7 mm	28016W
	27191	27191	9 mm	28060W
			Parmesan cheese	28061W
			Röstis potatoes	27164W
		Raw potatoes	27219W	
		0.7 mm horseradish paste		
		1 mm horseradish paste	28055W	
		1.3 mm horseradish paste		
JULIENNE			1 x 8 mm (ribbons)	28172W
	27080	27080	1 x 26 onion/cabbage	28153W
	27081	27081	2 x 4 mm	27072W
			2 x 6 mm	27066W
			2 x 8 mm	27067W
	27599	27599	2 x 10 mm (ribbons)	28173W
			2 x 2 mm	28051W
			2.5 x 2.5 mm	28195W
	27047	27047	3 x 3 mm	28101W
	27610	27610	4 x 4 mm	28052W
	27048	27048	6 x 6 mm	28053W
		8 x 8 mm	28054W	

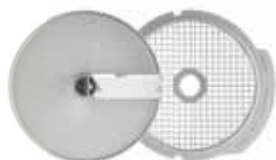

ESSENTIAL Series 1-4

R 301 Ultra	R 402 V.V.
-------------	------------

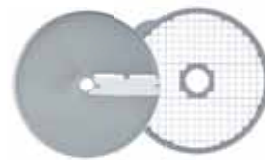

EXPERT Series 5-7

R 502 V.V. R 752 V.V.
CL 50 Ultra / CL 52 CL 55 / CL 60

DISCS

DICING EQUIPMENT



FRENCH FRIES



	R 301 Ultra	R 402 V.V.		R 502 V.V. R 752 V.V.	
			5 x 5 x 5 mm		■ 28110W
		■ 27513W	8 x 8 x 8 mm		■ 28111W
		■ 27514W	10 x 10 x 10 mm		■ 28112W
		■ 27515W	12 x 12 x 12 mm		■ 28197W
			14 x 14 x 5 mm (mozzarella)		■ 28181W
			14 x 14 x 10 mm		■ 28179W
			14 x 14 x 14 mm		■ 28113W
			20 x 20 x 20 mm		■ 28114W
			25 x 25 x 25 mm		■ 28115W
			50 x 70 x 25 mm (salad)		■ 28180W
			6 x 6 mm* 		▲ 29230W
		▲ 27116W	8 x 8 mm		▲ 28134W
			8 x 16 mm		▲ 28159W
		▲ 27117W	10 x 10 mm		▲ 28135W
			10 x 16 mm		▲ 28158W
PACK OF DISCS	1904	1904	Pack of 4 discs		
	-	2195W	Pack of 6 discs		
			Pack of 7 discs		2023W
			Pack of 16 discs		2022W

■ **DICING equipment consisting of:** 1 dicing grid + 1 slicing disc.

▲ **FRENCH FRIES equipment consisting of:** 1 french fries grid + 1 special french fries cutting disc.

***6x6 mm French Fries equipment:**

- Compatible with the machines :

- CL 50 Ultra, R 502 V.V. With those machines, it must be used in addition to EasyLoader (page 41)
- CL 55 and CL 60 with Automatic Feed Head

- Not compatible with the machines :

- R 752 V.V., CL 52
- CL 55 and CL 60 with Pusher Feed Head

NEW

EasyClean Xpress

The zero waste solution to clean **EXPERT** dicing grids R 502 V.V. to R 752 V.V. and CL 50 Ultra to CL 60

- Fast, easy cleaning
- Zero waste
- Save 250 g / grid



For dicing grids	Ref.
8 mm	49305
10 mm	49309
12 mm	49313
14 mm	49314



NEW

D-Clean Kit

Dicing grid cleaning tool



Grid holder

- **ESSENTIAL** R 402 - CL 40
- **EXPERT** R 502 V.V. to R 752 V.V. - CL 50 Ultra to CL 60

+



Dicing grid cleaning tool

5 mm, 8 mm, 10 mm, 12 mm and 14 mm

+



Scraper tool

	Ref.
D-Clean Kit	29246

WALL MOUNTED BLADE AND DISC HOLDER:

1 BLADE and 8 DISCS
> R 402 V.V.

Ref.
107810



WALL MOUNTED DISC HOLDER WITH 4 STAINLESS STEEL HOOKS:

> 16 small discs or 8 large discs

Ref.
107812



DISC RACK:

> R 502 V.V. to R 752 V.V.
> CL 50 Ultra to CL 60

Ref.
27258



WALL MOUNTED DISC HOLDER STAINLESS STEEL

Ref.
101230



DISC PROTECTOR:

> R 502 V.V. to R 752 V.V.
> CL 50 Ultra to CL 60

Ref.
39726



THE TURNKEY SOLUTION FOR ALL KITCHENS

ESSENTIAL Series 1-4

ASIA PACK OF 4 DISCS

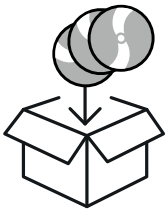

Slicers 2 mm & 4 mm
Graters 2 mm
Julienne 2 x 2 mm

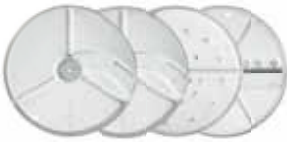

Ref.	
R 301 Ultra, R 402 V.V.	1904

Wall-mounted disc holders (set of 2) **FREE**

PACK OF 6 DISCS

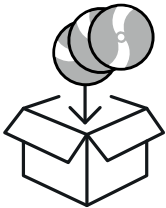

Slicers 2 mm & 4 mm
Graters 2 mm
Julienne 2 x 2 mm* & 4 x 4 mm**
Dicing Equipment 10 x 10 x 10 mm

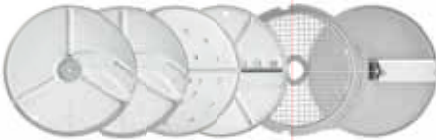

*with 2195 / **with 1945

Ref.	
R 402 V.V.	2195W

Wall-mounted disc holders (set of 2) **FREE**

EXPERT Series 5-7

ASIA PACK OF 7 DISCS

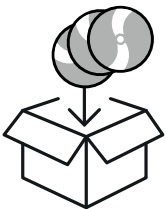

Slicers 2 mm & 5 mm
Graters 2 mm
Julienne 2 x 2 mm & 3 x 3 mm
Dicing Equipment 10 x 10 x 10 mm



Ref.	
R 502 V.V., R 752 V.V., CL 50 Ultra, CL 52, CL 55, CL 60	2023W

Wall-mounted disc holders (set of 2) **FREE**

MULTICUT PACK OF 16 DISCS

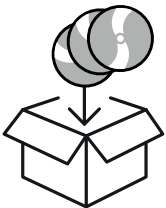

Slicers 1 mm, 2 mm, 4 mm
Graters 1.5 mm, 3 mm
Julienne 2.5 x 2.5 mm, 2 x 10 mm, 4 x 4 mm



Dicing Equipment 5 x 5 x 5 mm, 10 x 10 x 10 mm, 20 x 20 x 20 mm
French Fries Equipment 10 x 10 mm



Fruit and vegetables in all shapes and sizes

With evolving nutritional requirements, chefs in the mass catering sector are looking for solutions to serve more raw fruits and vegetables.

It is a great opportunity for chefs to provide creative & original cuts, in addition to presenting fresh fruit and vegetables in a more attractive way.

Robot Coupe's latest and most innovative launch, the Multicut Pack comes with 16 discs included!

Ref.	
MultiCut Pack of 16 discs	2022W

2 wall-mounted disc holders (set of 2) **FREE**



3 Solutions from Robot-Coupe To slice tomatoes and achieve A flawless glazed cut



1 CL 50 Continuous ejection Small and large quantities



**BOOST
PRODUCTIVITY**

6 kg = 1 min



2 CL 50 + Mini bowl Slice up to 9 tomatoes ready to use



	Ref.
Mini Bowl (R 502 V.V. - CL 50 Ultra)	39716



3 CL 50 + EasyStacker Slice and stack 1 tomato at one time



NEW

	Ref.
EasyStacker (CL 50 Ultra)	49332





Robot-Coupe's French fry solutions

5 sizes = the widest range of cuts



NEW
French fry equipment
6x6 mm : Fresh fries for
all your cravings!

BOOST PRODUCTIVITY
6 kg = 1 min

- Extremely quick cooking time
- Fries that are crisper than ever
- Higher yield

NEW
EasyLoader

- Continuous feeding for increased productivity.
- Making beautiful and large fries thanks to an optimized potato cutting on the length.



BOOST PRODUCTIVITY
25 kg = 4 min

		Ref.
EasyLoader (R 502 V.V. & CL 50 Ultra)	1	49323
6x6 mm French Fry attachment (R 502 V.V. & CL 50 Ultra)	1 + 2	49324
8x8 mm French Fry attachment (R 502 V.V. & CL 50 Ultra)	1 + 2	49325
8x16 mm French Fry attachment (R 502 V.V. & CL 50 Ultra)	1 + 2	49326
10x10 mm French Fry attachment (R 502 V.V. & CL 50 Ultra)	1 + 2	49327
10x16 mm French Fry attachment (R 502 V.V. & CL 50 Ultra)	1 + 2	49328
6x6 mm French Fry equipment (CL 55 & CL 60 Auto)*	2	29230W

*Not compatible with R 752 V.V. - CL 52 - CL 55 Pusher - CL 60 Pusher
For CL 50 Ultra & 502 V.V. it must be used in addition to EasyLoader.



NEW Surface treatment:
Series 5-7



High Resistance

This mineral-based treatment provides optimum protection of the disc surface.



Freshness is preserved

This treatment reduces friction on the disc, ensures perfect cutting and keeps fruit and vegetables fresh.



Easy Cleaning

Dishwasher resistant.

These new discs can be identified : new appearance and letter W included in the item code.



















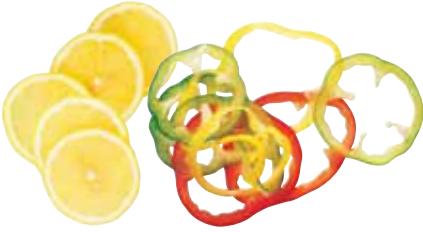





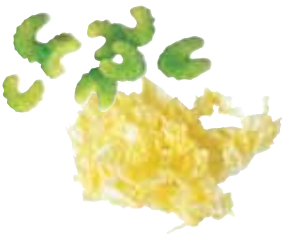

THE WIDEST RANGE OF CUTS

SLICERS



EXPERT CL 50 Ultra, CL 52, CL 55, CL 60, R 502 V.V. or R 752 V.V.

ESSENTIAL R 301 Ultra, R 402 V.V.

 <p>Almonds 0.6 mm Ref. 28166W</p> 	 <p>0.8 mm Ref. 28069W</p> 	 <p>1 mm Ref. 28062W Ref. 27051</p> 	
 <p>2 mm Ref. 28063W Ref. 27555</p> 	 <p>3 mm Ref. 28064W Ref. 27086</p> 	 <p>4 mm Ref. 28004W Ref. 27566</p> 	
 <p>5 mm Ref. 28065W Ref. 27087</p> 	 <p>6 mm Ref. 28196W Ref. 27786</p> 	 <p>8 mm Ref. 28066W</p> 	 <p>10 mm Ref. 28067W</p> 
 <p>14 mm Ref. 28068W</p> 	 <p>Cooked potatoes 4 mm Ref. 27244W</p> 	 <p>Cooked potatoes 6 mm Ref. 27245W</p> 	

The green discs show the actual size



GRATERS

EXPERT CL 50 Ultra, CL 52, CL 55, CL 60, R 502 V.V. or R 752 V.V.

ESSENTIAL R 301 Ultra, R 402 V.V.



1.5 mm
Ref. 28056W
Ref. 27588



2 mm
Ref. 28057W
Ref. 27577

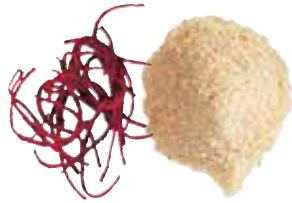

3 mm
Ref. 28058W
Ref. 27511



4 mm
Ref. 28073W



5 mm
Ref. 28059W



6 mm
Ref. 27046



7 mm
Ref. 28016W



9 mm
Ref. 28060W
Ref. 27632



Parmesan cheese
Ref. 28061W
Ref. 27764



Röstis potatoes
Ref. 27164W
Ref. 27191



Raw potatoes
Ref. 27219W



Horseradish
Ref. 28055W 1 mm
Ref. 27078 0.7 mm
Ref. 27079 1 mm
Ref. 27130 1.3 mm



RIPPLE CUT

EXPERT CL 50 Ultra, CL 52, CL 55, CL 60, R 502 V.V. or R 752 V.V.

ESSENTIAL R 301 Ultra, R 402 V.V.



2 mm
Ref. 27068W

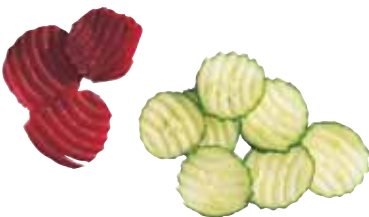

3 mm
Ref. 27069W
Ref. 27622 **NEW**



5 mm
Ref. 27070W
Ref. 27623 **NEW**



The green discs show the actual size











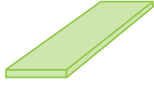

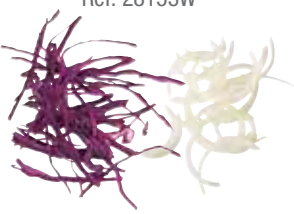





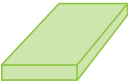

THE WIDEST RANGE OF CUTS

JULIENNE

EXPERT CL 50 Ultra, CL 52, CL 55, CL 60, R 502 V.V. or R 752 V.V.

ESSENTIAL R 301 Ultra, R 402 V.V.



 1 x 8 mm ribbons Ref. 28172W 	 1 x 26 mm onions & cabbage Ref. 28153W 	 2 x 4 mm Ref. 27072W Ref. 27080 	 2 x 6 mm Ref. 27066W Ref. 27081 
 2 x 8 mm Ref. 27067W 	 2 x 10 mm Tagliatelles Ref. 28173W 	 2 x 2 mm Ref. 28051W Ref. 27599 	 2,5 x 2,5 mm Ref. 28195W 
 3 x 3 mm Ref. 28101W 	 4 x 4 mm Ref. 28052W Ref. 27047 	 6 x 6 mm Ref. 28053W Ref. 27610 	 8 x 8 mm Ref. 28054W Ref. 27048 

FRENCH FRIES









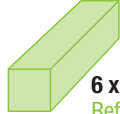

EXPERT CL 50 Ultra, CL 52, CL 55, CL 60, R 502 V.V. or R 752 V.V.

EXPERT CL 50 Ultra, R 502 V.V. (Equipment + EasyLoader*)

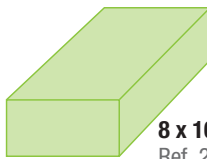
EXPERT CL 55 Auto, CL 60 Auto (French fry Equipment only)

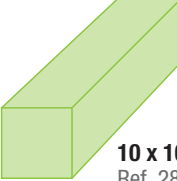
ESSENTIAL R 402 V.V.

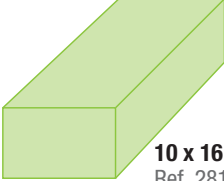

 6 x 6 mm Ref. 49324 Ref. 29230W 	 8 x 8 mm Ref. 28134W Ref. 27116W 	 8 x 16 mm Ref. 28159W 	 10 x 10 mm Ref. 28135W Ref. 27117W 	 10 x 16 mm Ref. 28158W 
--	---	---	---	--

*Discover EasyLoader page 48

The green discs show the actual size



DICING EQUIPMENT

EXPERT CL 50 Ultra, CL 52, CL 55, CL 60, R 502 V.V. or R 752 V.V.

ESSENTIAL R 402 V.V.

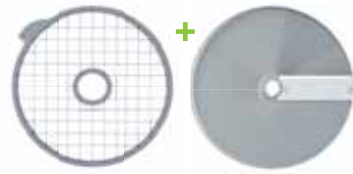

5x5x5 mm
Ref. 28110W

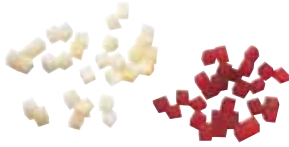

8x8x8 mm
Ref. 28111W
Ref. 27513W



10x10x10 mm
Ref. 28112W
Ref. 27514W



12x12x12 mm
Ref. 28197W
Ref. 27515W



14x14x5 mm
Ref. 28181W



14x14x10 mm
Ref. 28179W

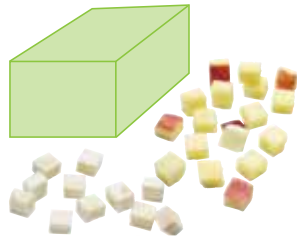

14x14x14 mm
Ref. 28113W

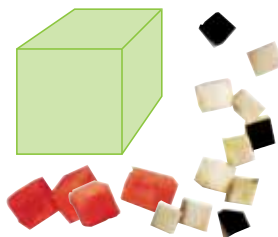

20x20x20 mm
Ref. 28114W

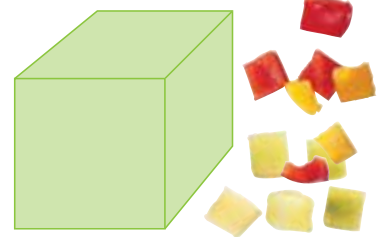

25x25x25 mm
Ref. 28115W



50x70x25 mm Salads
Ref. 28180W



NEW

EasyClean Xpress

The zero waste solution to clean **EXPERT** dicing grids R 502 V.V. to R 752 V.V. and CL 50 Ultra to CL 60

- Fast, easy cleaning
- Zero waste
- Save 250 g / grid



For dicing grids	Ref.
8 mm	49305
10 mm	49309
12 mm	49313
14 mm	49314



NEW

D-Clean Kit

Dicing grid cleaning tool



- **ESSENTIAL** R 402 - CL 40
- **EXPERT** R 502 V.V. to R 752 V.V. - CL 50 Ultra to CL 60

+



Dicing grid cleaning tool
5 mm, 8 mm, 10 mm, 12 mm and 14 mm

+



Scraper tool

	Ref.
D-Clean Kit	29246

[BACK TO SUMMARY](#)

POTATO RICER

R 502 V.V. - R 752 V.V.

CL 50 Ultra - CL 52 - CL 55 - CL 60

• **High output**

Can produce up to 10 kg of delicious fresh mashed potato in just 2 minutes.

• **Ergonomic**

The extra large ergonomic hopper allows for the continuous processing of potatoes with as little handling as possible.

• **Versatile**

In addition to the 50 existing ways of processing fruit and vegetables, you can also make puree.



The Potato Ricer Attachment consists of:

- a feed hopper to handle large quantities of potatoes (for R 502 V.V. and CL 50 Ultra only)
- a paddle
- a special Ø 3 mm or 6 mm grid
- a special puree ejection disc.

		Ref.
Potato Ricer Attachment Ø 3 mm (R 502 V.V. and CL 50 Ultra)	1 + 2	28207
Potato Ricer Equipment Ø 3 mm (R 752 V.V., CL 52, CL 55 and CL 60)	2	28208
Potato Ricer Attachment Ø 6 mm (R 502 V.V. and CL 50 Ultra)	1 + 2	28209
Potato Ricer Equipment Ø 6 mm (R 752 V.V., CL 52, CL 55 and CL 60)	2	28210



PREPARED ON SITE WITH ROBOT-COUCPE

Prepare your own potato dishes and add that all important "Homemade" claim.



Robot-Coupe offers many solutions for preparing homemade potato dishes with and without the skin:

Potato chips of every shape and size!

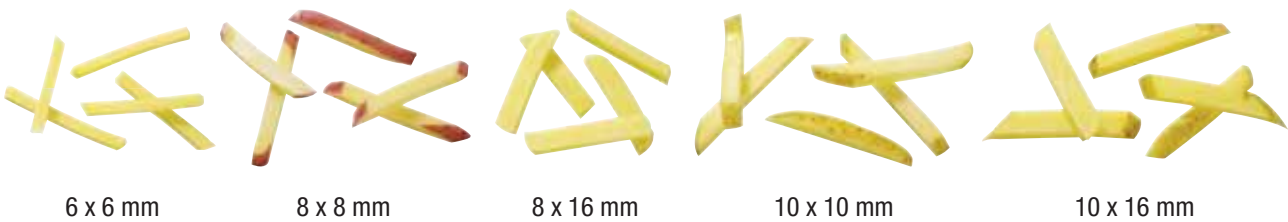

Shoestring fries



2 x 2 mm

Potato straws



4 x 4 mm



6 x 6 mm

Waffle-cut chips



2 x 2 mm

Pan-fried potatoes



14 x 14 mm or 20 x 20 mm

Potato crisps



1 or 2 mm

Scalloped Potatoes



5 mm

Mashed potatoes



VEGETABLE PREPARATION MACHINES

TABLE-TOP VEGETABLE PREPARATION MACHINES

p.50

FLOOR STANDING VEGETABLE PREPARATION MACHINES

p.56



THE WIDEST RANGE OF CUTS

Thanks to our range of Vegetable Preparation Machines, you can save hours of preparation in the kitchen: slicing, grating, chopping, shredding, julienne, brunoises, chip cutting, waffle cuts and even purees.



TABLE-TOP

VEGETABLE PREPARATION MACHINES

Large hopper

to insert large vegetables such as cabbage and eggplant... and optimised loading of other vegetables.



Hinge and stem system

designed for instant removal of the lid for easy cleaning.

Easy Guide

Stainless steel motor body

Cylindrical hopper

- Ø 58 mm uniform cutting of long ingredients.
- Ø 39 mm to cut up small fruit and vegetables such as chillis, gherkins, dry sausage, asparagus, spring onions, bananas, strawberries, grapes, etc. with the Exactitube pusher.



INDUCTION MOTOR

Lateral ejection
Space saving and convenient to use.



More than 50 optional discs for slicing, ripple cutting, grating, chopping, chip cutting and julienne.



INNOVATION

EXACTITUBE PUSHER

The secret of exclusive cuts!
For slicing small and delicate ingredients such as chillis, gherkins, dry sausage, asparagus, spring onions, bananas, strawberries and grapes.



BOOST PRODUCTIVITY

Up to 20kg = 4 min*

Sliced cucumbers



*The data may vary depending on the cuts and ingredients.

THE WIDEST RANGE OF CUTS

Robot-Coupe vegetable preparation machines have more than 50 discs to process not only fruit and vegetables but also cheese and sausage.



POTATO RICER

CL 50 Ultra, CL 52, CL 55, CL 60



Potato Ricer Attachment



Feed hopper (for CL 50 Ultra only).



Paddle
Puree grid:
3 mm or 6 mm

Special ejection disc

Potato Ricer Equipment

The Potato Ricer Attachment consists of:

- a feed hopper to handle large quantities of potatoes (for CL 50 Ultra only)
- a paddle
- a special Ø 3 mm or 6 mm grid
- a special puree ejection disc.



		Ref.
Potato Ricer Attachment Ø 3 mm (CL 50 Ultra)	1 + 2	28207
Potato Ricer Equipment Ø 3 mm	2	28208
Potato Ricer Attachment Ø 6 mm (CL 50 Ultra)	1 + 2	28209
Potato Ricer Equipment Ø 6 mm	2	28210

TABLE-TOP VEGETABLE PREPARATION MACHINES



Effective throughput
per hour:



Up to 150 kg

GRATING / SLICING / RIPPLE-CUT / JULIENNE

+ DICING + FRENCH FRIES



CL 50 Ultra



- Single phase
- 1 speed
- Potato Ricer Attachment*

Find all our floor standing models on page 58





Effective throughput per hour:



Up to 250 kg

GRATING / SLICING / RIPPLE-CUT / JULIENNE

+ DICING + FRENCH FRIES



CL 52



- Single phase
- 1 speed
- Potato Ricer Equipment*

*Optional attachments



TABLE-TOP VEGETABLE PREPARATION MACHINES



D-Clean Kit

Area 139 cm²



D-Clean Kit

Area 227 cm²

CL 50 Ultra

Motor	Induction
Power	550 W
Voltage	Single phase
Speed	375 rpm
Feed hoppers	Half moon hopper 2.2 L Cylindrical hopper Ø 58 mm and Ø 39 mm, Exactitube pusher - Included
Lid and bowl	Metal
Motor base	Stainless steel
Accessories	-
D-Clean Kit	Included
Discs	Not included

Choose your model:



CL 50 Ultra	Ref.
CL 50 Ultra 230V/50/1 UK plug	24470

CL 52

Motor	Induction
Power	750 W
Voltage	Single phase
Speed	375 rpm
Feed hoppers	Full moon hopper 4.4 L Cylindrical hopper Ø 58 mm and Ø 39 mm, Exactitube pusher - Included
Lid and bowl	Metal
Motor base	Stainless steel
Accessories	Motor shaft brush - Included
D-Clean Kit	Included
Discs	Not included

CL 52	Ref.
CL 52 230V/50/1 UK plug	24492

Discover our selection of discs and packs on page 38



Choose your options:

Options	CL 50 Ultra		CL 52	
	Ref.		Ref.	
Additional Exactitube pusher	49212		49221	
Potato Ricer Attachment 3 mm	28207		-	-
Potato Ricer Attachment 6 mm	28209		-	-
Potato Ricer Equipment 3 mm	-	-	28208	
Potato Ricer Equipment 6 mm	-	-	28210	
Motor shaft brush	-	-	49257	

CL 52

Designed to cut up large amounts of vegetables in no time at all.



- Requires less effort
- Prevents MSD
- Takes away the painfulness of work

INNOVATION



EXTRA ERGONOMIC
Lever with assisted movement = less effort for the operator + increase throughput.



INDUCTION MOTOR



LATERAL EJECTION
Space saving and less strain.

Special cabbage tool for better ejection.



HIGH PRECISION

Cylindrical hopper

- Ø 58 mm uniform cutting of long ingredients.
- Ø 39 mm to cut up small fruit and vegetables such as chillis, gherkins, dry sausage, asparagus, spring onions, bananas, strawberries, grapes, etc. with the Exactitube pusher.

EXTRA LARGE

The very wide opening of the hopper is designed to take up to 15 tomatoes at a time.



Easy Guide

EXTRA POWERFUL

Stainless steel motor base for easy maintenance.
750 W ultra-powerful silent commercial grade motor.

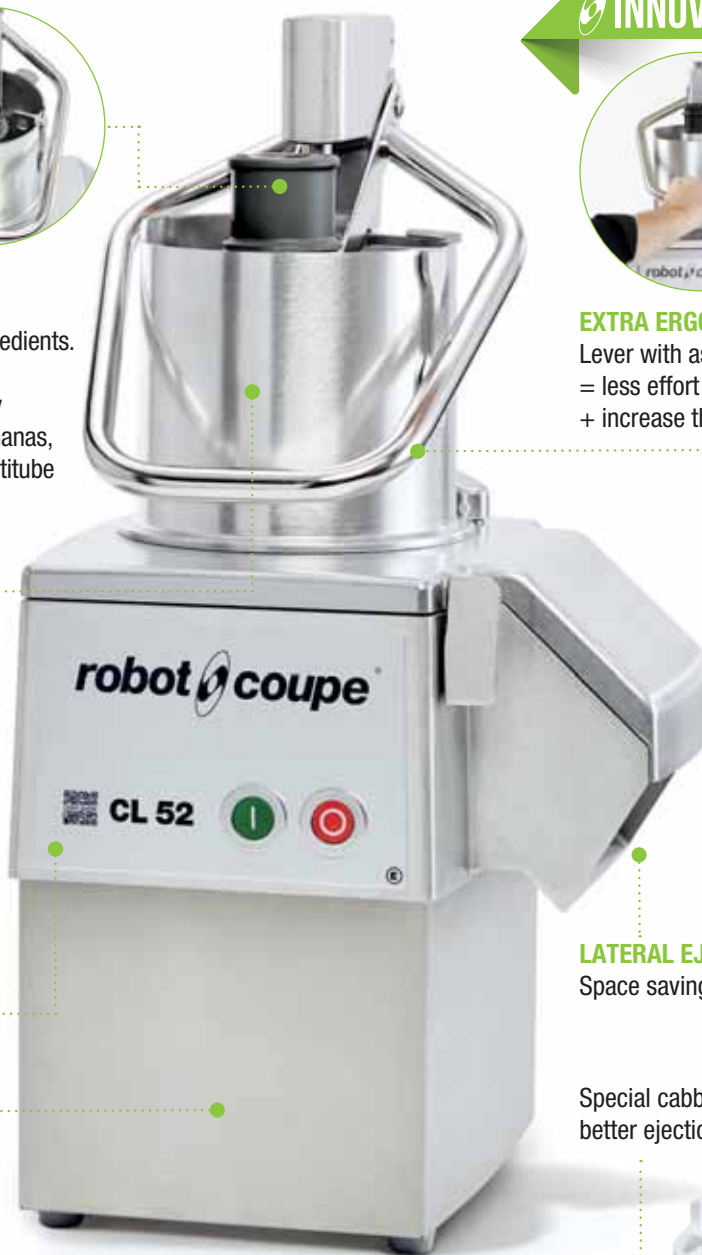

FLOOR STANDING VEGETABLE PREPARATION MACHINES

Especially designed for the preparation of large quantities of vegetables.

HIGH PRECISION

Cylindrical hopper

- Ø 58 mm uniform cutting of long ingredients.
- Ø 39 mm to cut up small fruit and vegetables such as chillis, gherkins, dry sausage, asparagus, spring onions, bananas, strawberries, grapes, etc. with the Exactitube pusher.

EXTRA LARGE

The very wide opening of the hopper is designed to take up to 15 tomatoes at a time.

Easy Guide

POWERFUL MOTOR

1500 W silent induction motor for durability.
Stainless steel motor base for easy cleaning.



INDUCTION
MOTOR

INNOVATION

EXTRA ERGONOMIC

Lever with assisted movement = less effort for the operator + increase throughput.



- Requires less effort
- Prevents MSD
- Takes away the tediousness

LATERAL EJECTION

Space-saving and user comfort.



CL 55 automatic feed-head



CL 55 pusher feed-head
(Surface area 227 sq.cm.)
with built-in tube



CL 55 4-tube feed head
2 Ø 50 mm tubes / 2 Ø 70 mm tubes



CL 55 2-tube feed head
Straight and slanted tubes

FLOOR STANDING VEGETABLE PREPARATION MACHINES



Practical throughput per hour:



400 kg



600 kg

GRATING / SLICING / RIPPLE-CUT / JULIENNE

+ DICING + FRENCH FRIES



CL 55 2 Feed-Heads



- Single phase or Three phase
- 1 or 2 speeds
- Potato Ricer Equipment*

CL 60 2 Feed-Heads



- Three phase
- 2 speeds
- Potato Ricer Equipment*

Find all our table-top models on page 52

*Optional attachments



600
1200+
600 kg

GRATING / SLICING / RIPPLE-CUT / JULIENNE

+ DICING + FRENCH FRIES

OPTIONAL
+
50
DISCS

CL 60 Workstation



- Three phase
- 2 speeds
- Potato Ricer Equipment

VEG PREP
MACHINES



[BACK TO SUMMARY](#)

FLOOR STANDING VEGETABLE PREPARATION MACHINES



CL 55 2 Feed-Heads

Motor	Induction	
Power	750 W	1 100 W
Voltage	Single phase	Three phase
Speed	375 rpm	375 rpm - 750 rpm
Feed-Heads	Stainless steel automatic feed tube Full moon pusher feed head 4.4 L Cylindrical hoppers Ø 58 mm and Ø 39 mm, Exactitube pusher - Included	
Lid and bowl	Metal	
Motor base	Stainless steel	
Mobile stand	Stainless steel Equipped with 2 wheels and brake	
Accessories	Motor shaft brush - Included	
D-Clean Kit	Included	
Discs	Not included	

Choose your model:

CL 55 2 Feed-Heads	Ref.
CL 55 2 Feed-Heads 230V/50/1 UK plug	2073
CL 55 2 Feed-Heads 400V/50/3	2211

Discover our selection of discs and packs on page 38



Choose your pack of discs:

						Ref.
Asia Pack of 7 discs						
Slicers 2 mm - 5 mm	Grater 2 mm	Julienne 2x2 mm - 3x3 mm	Dicing Equipment 10x10x10 mm	Wall disc holder		2023W
MultiCut Pack of 16 discs						
Slicers 1 mm - 2 mm 4 mm	Grater 1.5 mm 3 mm	Julienne 2.5 x 2.5 mm 2 x 10 mm - 4 x 4 mm	Dicing Equipment 5 x 5 x 5 mm - 10 x 10 x 10 mm 20 x 20 x 20 mm	French Fries Equipment 10x10x10 mm	Wall disc holder x2	2022W

CL 55 ACCESSORIES



Automatic feed-head
Ref. 28170 -



Pusher feed-head
with built-in tube
(surface area 227 sq.cm.)
Ref. 39673 -



4-tubes feed-head
2 Ø 50 mm tubes
2 Ø 70 mm tubes
Ref. 28161 -



Straight and bias tubes
Ref. 28155 -



Potato Ricer
Ref. 28208 Ø 3 mm
Ref. 28210 Ø 6 mm



Exactitube pusher
CL 52 - CL 55 - CL 60
Ref. 49221 -



Motor shaft brush
Ref. 49257 -



3-height adjustable trolley GN1x1
Delivered without container
Ref. 49128 -



Storage trolley for 16 discs, 8 attachments and 3 feed heads, delivered with 1 GN1x1 container (attachments not included)
Ref. 49132 -

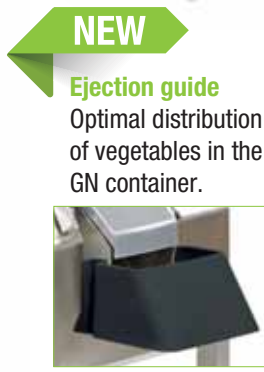

CL 60 2 Feed-Heads

Motor	Induction
Power	1 500 W
Voltage	Three phase
Speed	375 rpm - 750 rpm
Feed-Heads	Stainless steel automatic feed tube Full moon pusher feed-head 4.9 L Cylindrical hopper Ø 58 mm and Ø 39 mm, Exactitube pusher - Included
Bowl	Stainless steel
Motor base	Stainless steel
Equipped with	1 adjustable foot for all floor types 2 wheels 1 stainless steel container for cutting attachments
Accessories	Motor shaft brush - Included Included
Discs	Not included

Choose your model:

CL 60 2 Feed-Heads without disc	Ref.
CL 60 2 Feed-Heads 400V/50/3	2325FA



Discover our selection of discs and packs on page 38



Choose your pack of discs:

						Ref.
Asia Pack of 7 discs						
Slicers 2 mm - 5 mm	Grater 2 mm	Julienne 2x2 mm - 3x3 mm	Dicing Equipment 10x10x10 mm	Wall disc holder		2023W
MultiCut Pack of 16 discs						
Slicers 1 mm - 2 mm 4 mm	Grater 1,5 mm 3 mm	Julienne 2,5 x 2,5 mm 2 x 10 mm - 4 x 4 mm	Dicing Equipment 5 x 5 x 5 mm - 10 x 10 x 10 mm 20 x 20 x 20 mm	French Fries Equipment 10x10x10 mm	Wall disc holder x2	2022W

CL 60 ACCESSORIES



Automatic feed-head
With feeding tray
Ref. 49681 -



Pusher feed-head
Ref. 39680 -



4 tubes feed-head
2 Ø 50 mm tubes
2 Ø 70 mm tubes
Ref. 49682 -



Straight and bias tubes
Ref. 28157 -



Potato Ricer
Ref. 28208 Ø 3 mm
Ref. 28210 Ø 6 mm



Exactitube pusher
CL 52 - CL 55 - CL 60
Ref. 49221 -



Motor shaft brush
Ref. 49257 -



Ergo mobile trolley
Supplied without container.
Designed to take 3 GN1x1
gastronorm containers
Ref. 49066 -



Storage trolley for 16 discs, 8 attachments and 3 feed heads, delivered with 1 GN1x1 container (attachments not included)
Ref. 49132 -

CL 60 Workstation

Up to 1800 kg of vegetables an hour*



STORAGE TROLLEY



Adjustable leg
so it can be adapted to uneven floors and ensure stability.



CL 60 Workstation

Motor	Induction
Power	1 500 W
Voltage	Three phase
Speed	375 rpm - 750 rpm
Feed-Heads	Stainless steel automatic feed head Full moon pusher feed head 4.9 L Cylindrical hopper Ø 58 mm and Ø 39 mm, Exactitube pusher - Included 4 tubes: 2 Ø 50mm tubes and 2 Ø 70mm tubes
Lid and bowl	Metal
Motor base	Stainless steel
Equipped with	1 adjustable foot for all floor types 2 wheels 1 stainless steel container for cutting attachments.
Accessories	Ergo mobile trolley with 3 GN1x1 gastronorm containers - Included Storage trolley with 1 GN1x1 gastronorm container - Included 3 mm Potato Ricer Equipment - Included Motor shaft brush - Included
D-Clean Kit	Included
Discs	MultiCut Pack of 16 discs - Included

NEW

Ejection guide
Optimal distribution of vegetables in the GN container.



BOOST PRODUCTIVITY

Up to 50 kg in 5 min**
French Fries



**The data may vary depending on the cuts and ingredients.

CL 60 Workstation	Ref.
CL 60 Workstation 400V/50/3	2300FA

*Theoretical throughput

A COMPLETE COLLECTION OF ATTACHMENTS INCLUDED!



Automatic feed-head

For all bulky vegetables (tomatoes, onions, potatoes, etc.).



Pusher feed-head

Especially designed for bulky vegetables such as cabbage and celeriac.



4 tubes feed-head

Especially designed for long vegetables such as cucumbers and zucchini.



Exactitube pusher

For cutting up small sized fruit and vegetables such as chillis, gherkins, dry sausage, asparagus, spring onions, bananas, strawberries and grapes.



3 mm Potato Ricer Equipment

To easily produce large quantities of mashed potatoes.



Storage trolley

To store and transport all the attachments! Tray for 16 discs and 8 attachments. GN1X1 container for kitchen utensils.



Motor shaft brush



MultiCut Pack

16 discs included.



1 mm

2 mm

4 mm

1.5 mm

3 mm

Slicers

Graters

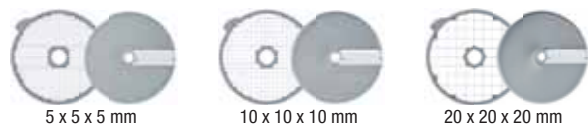

5 x 5 x 5 mm

10 x 10 x 10 mm

20 x 20 x 20 mm

Dicing Equipment

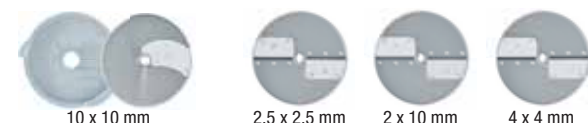

10 x 10 mm

2.5 x 2.5 mm

2 x 10 mm

4 x 4 mm

French Fries

Juliennes



4 wall mounted disc holders for 16 discs

Ergo Mobile Trolley

To transport, load and store accessories.
3 GN1x1 gastronorm containers provided.



CUTTERS MIXERS

TABLE TOP CUTTER MIXERS

p.66

FLOOR STANDING VERTICAL CUTTER MIXERS

p.74



THE MUST FOR PASTRY AND KITCHEN CHEFS!

With its bowl-base twin-blade assembly - a Robot-Coupe exclusivity - it is the Chef's ideal assistant. Whether you need small or large quantities, all your preparations can be made by just pressing a button: sauces, minced meat and fish, chopped onions, herbs and spices, ground nuts and chocolate, praline, kneading, etc.



TABLE TOP CUTTER MIXERS

LID

Liquids and other ingredients can be added during processing.

BOWL

7.5L: to save time by increasing the quantities processed.

ERGONOMIC HANDLE

Soft touch handle designed for more comfort and for a firm and secure grip.

Easy Guide



INNOVATION

BOWL-BASE TWIN-BLADE ASSEMBLY

To process both large and small quantities. All stainless steel with detachable smooth blade. Optional coarse and fine serrated blade.

Variable speed models:

300 to 3 500 rpm for more flexible use and a greater variety of applications.

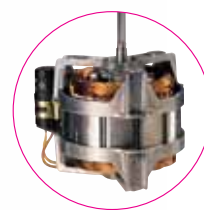



















INDUCTION MOTOR

TIMER

Less effort, greater precision and more regular results no matter what the recipe.



 <p>Smooth blade As standard</p>		  COARSE CHOPPING	  FINE CHOPPING	  SAUCES, EMULSIONS	
		 <p>Coarse serrated blade ESPECIALLY for grinding & kneading</p>		  KNEADING	  GRINDING
				 <p>Fine serrated blade ESPECIALLY for herbs & spices</p>	

 <p>BOOST PRODUCTIVITY</p>	<p>R 7 V.V.</p> <p>4 kg = 2 min</p> <p>Almond powder</p>	

R-MIX FUNCTION R-Mix®

On R 5 V.V., R 7 V.V.

- To blend delicate ingredients without chopping.
- The R-Mix® function is designed for reverse rotation blending at variable speeds from 60 to 500 rpm to incorporate whole pieces of meat, crayfish tails, brunoises and diced vegetables to pâtés and terrines, whole raisins to buns, etc.



TABLE-TOP CUTTER MIXERS



Quantities*



1 kg



1.5 kg



2.5 kg

VARIABLE SPEED from 300 to 3 500 rpm

R 4 V.V.

OPTIONAL
3
BLADES

4.5 L



- Single phase

1 SPEED 3 000 rpm

R 3-3000

OPTIONAL
3
BLADES

3.7 L



- Single phase

1 SPEED 1 500 rpm

R 2

OPTIONAL
3
BLADES

2.9 L



- Single phase

*Maximum quantities processed at a time



3 kg



3.5 kg



5 kg

VARIABLE SPEED from 300 to 3 500 rpm

R 5 V.V.



OPTIONAL
3
BLADES
5.9 L

- Single phase
- R-Mix®

R 7 V.V.



OPTIONAL
3
BLADES
7.5 L

- Single phase
- R-Mix®

2 SPEEDS 1 500 and 3 000 rpm

R 8



OPTIONAL
3
BLADES
8 L

- Three phase

R-Mix®: Reverse rotation blending function

PERFORMANCE RATES

Models	Maximum capacity				Number of covers	Time
	Coarse chopping (up to)	Emulsions (up to)	Pastry/dough* (up to)	Grinding (up to)		
R 2	0,8 kg	1 kg	0,5 kg	0,3 kg	1 to 50	1 to 4 minutes
R 3	1 kg	1,5 kg	1 kg	0,5 kg	1 to 50	
R 4 V.V.	1,5 kg	2,5 kg	1,5 kg	0,7 kg	50 to 100	
R 5 V.V.	2,2 kg	3,2 kg	2,2 kg	1,1 kg	50 to 200	
R 7 V.V.	2,7 kg	3,8 kg	2,7 kg	1,7 kg	100 to 200	
R 8	3 kg	5 kg	4 kg	2 kg	200 to 300	

*Amount of raised dough with 60% hydration

Find all our floor standing models on page 76

TABLE-TOP CUTTER MIXERS



R 2

Motor	Induction
Power	550 W
Voltage	Single phase
Speed	1 500 rpm
Pulse	✓
Bowl	2.9 L stainless steel
Blade	Stainless steel smooth blade Included

R 3 - 3000

Motor	Induction
Power	650 W
Voltage	Single phase
Speed	3 000 rpm
Pulse	✓
Bowl	3.7 L stainless steel
Blade	Stainless steel smooth blade Included

R 4 V.V.

Motor	Induction
Power	1 000 W
Voltage	Single phase
Speed	300 to 3 500 rpm
Pulse	✓
Bowl	4.5 L stainless steel
Blade	Stainless steel smooth blade Included

Choose your model:



R 2	Ref.
R 2 230V/50/1 UK plug	22107D

R 3-3000	Ref.
R 3-3000 230V/50/1 UK plug	22389

R 4 V.V.	Ref.
R 4 V.V. 230V/50-60/1 UK plug	22412M

Choose your options:



	R 2	R 3	R 4
Options	Ref.	Ref.	Ref.
Coarse serrated blade Especially for grinding & kneading	27138	27288	27346
Fine serrated blade Especially for herbs & spices	27061	27287	27345
Additional smooth blade	27055	27286	27344



R 5 V.V.

Motor	Induction
Power	1 500 W
Voltage	Single phase
Speed	300 to 3 500 rpm
Timer	✓
Pulse	✓
Motor base	Metal
Bowl	5.9 L stainless steel
Blade	Stainless steel smooth blade - Included Blade cleaning tool - Included
R-Mix®	✓

Choose your model:



R 5 V.V.	Ref.
R 5 V.V. 230V/50-60/1 UK plug	24623M



R 7 V.V.

Motor	Induction
Power	1 500 W
Voltage	Single phase
Speed	300 to 3 500 rpm
Timer	✓
Pulse	✓
Motor base	Metal
Bowl	7.5 L stainless steel
Blade	All stainless steel detachable, adjustable smooth blade assembly - Included
R-Mix®	✓

R 7 V.V.	Ref.
R 7 V.V. 230V/50-60/1 UK plug	24711M

Choose your options:



Options	R 5 V.V.		R 7 V.V.	
	Ref.		Ref.	
Coarse serrated blade Especially for grinding & kneading	27305	-	-	-
Fine serrated blade Especially for herbs & spices	27304	-	-	-
Additional smooth blade	27303	-	-	-
Stainless steel coarse serrated blade Especially for grinding & kneading	-	-	27308	
Stainless steel fine serrated blade Especially for herbs & spices	-	-	27307	
Additional stainless steel smooth blade	-	-	27306	
Lower coarse serrated blade	-	-	49162	
Upper coarse serrated blade	-	-	49163	
Lower fine serrated blade	-	-	49164	
Upper fine serrated blade	-	-	49165	
Lower smooth blade	-	-	49160	
Upper smooth blade	-	-	49161	
Scraper arm	49552		49552	
Blade cleaning tool	49258		-	-

TABLE-TOP CUTTER MIXERS



R 8

Motor	Induction
Power	2 200 W
Voltage	Three phase
Speed	1 500 rpm - 3 000 rpm
Pulse	✓
Bowl	8 L stainless steel
Blade	All stainless steel detachable, adjustable 2 smooth blade assembly - Included
R-Mix®	-

Choose your model:

R 8	Ref.
R 8 400V/50/3	21291



Choose your options:



Options	Ref.
Stainless steel coarse serrated 2-blade assembly Especially for grinding & kneading	27383
Stainless steel fine serrated 2-blade assembly Especially for herbs & spices	27385
Additional stainless steel 2 smooth blade assembly	27381
Coarse serrated blade	59281
Fine serrated blade	59282
Smooth blade	59280
Vacuum adaptation kit R-Vac (without pump)	29996
Vacuum pump 550 W 16 m ² 230V/50/1	69012



Optional additional mini bowl	Ref.
3.5 litre stainless steel bowl R 8 stainless steel smooth blade	27374
Stainless steel coarse serrated blade	27107
Additional stainless steel smooth blade	27106
Coarse serrated blade	101801S
Smooth blade	101800S



FLOOR STANDING VERTICAL CUTTER MIXERS

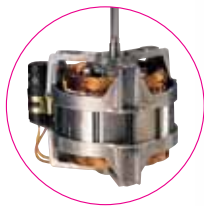

**INDUCTION
MOTOR**

Easy Guide

CONTROL PANEL
0 to 15 minute **timer**, **stainless steel flush mounted control buttons** and **pulse control** for greater cutting precision.

INNOVATION

STAINLESS STEEL BOWL-BASE BLADE ASSEMBLY
New Robot-Coupe patented blade profile for optimum cutting quality.

STAINLESS STEEL FRAME
All stainless steel with 3 sturdy built-in legs to ensure total stability, minimum space requirements and easy cleaning.

WHEELS INCLUDED
3 retractable wheels for easy moving and cleaning.

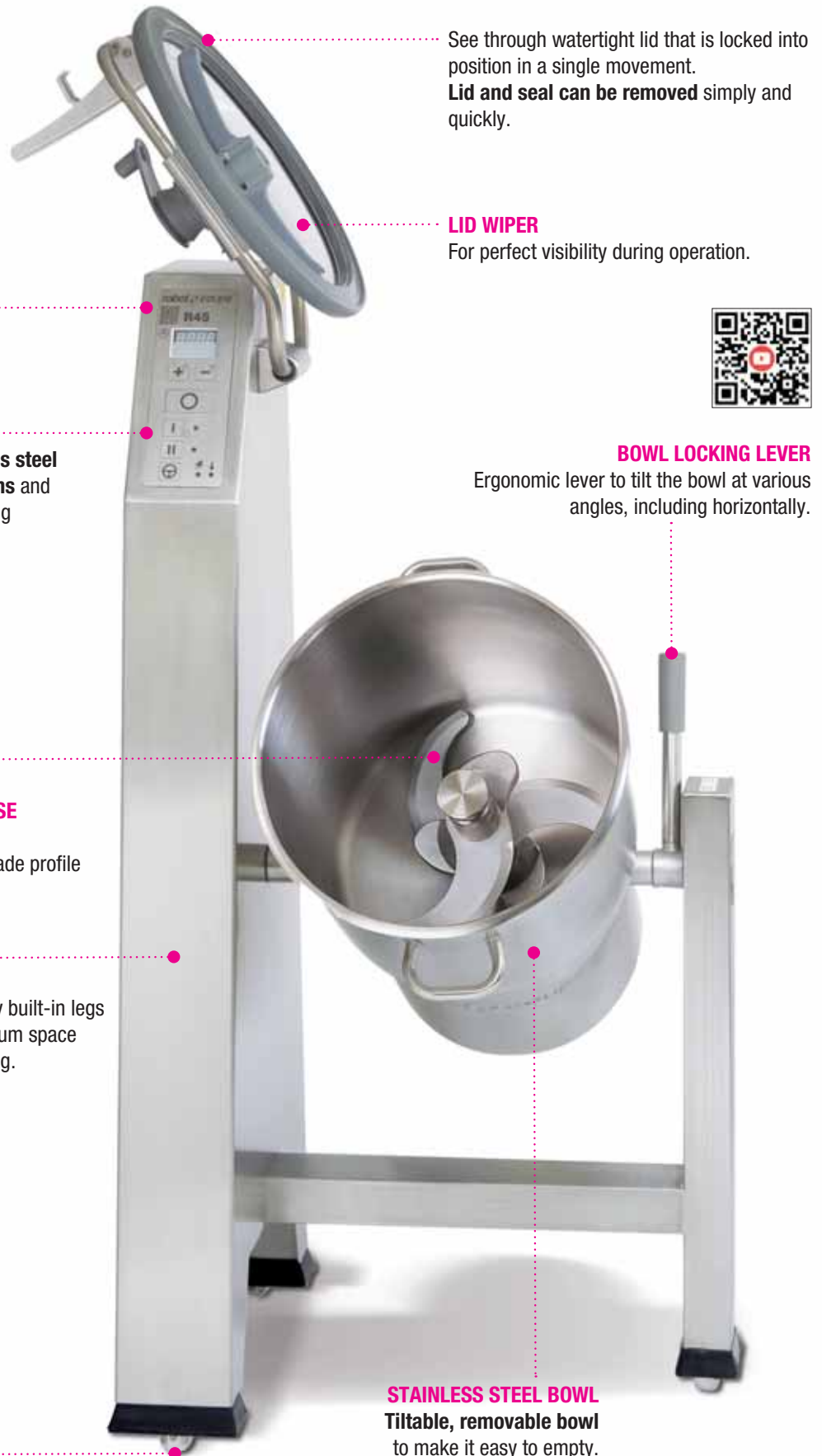

See through watertight lid that is locked into position in a single movement.
Lid and seal can be removed simply and quickly.











LID WIPER
For perfect visibility during operation.



BOWL LOCKING LEVER
Ergonomic lever to tilt the bowl at various angles, including horizontally.

STAINLESS STEEL BOWL
Tiltable, removable bowl to make it easy to empty.

3 BLADES FOR BEST RESULTS

 <p>Smooth blade As standard</p>	 <p>COARSE CHOPPING</p>	 <p>FINE CHOPPING</p>	 <p>SAUCES, EMULSIONS</p>
 <p>Coarse serrated blade ESPECIALLY for grinding & kneading</p>	 <p>KNEADING</p>	 <p>GRINDING</p>	
 <p>Fine serrated blade ESPECIALLY for herbs & spices</p>	 <p>CHOPPING HERBS</p>	 <p>GRINDING SPICES</p>	

VACUUM FUNCTION **R-Vac®**

The **R-Vac®** is designed for vacuum processing to obtain results of incomparable quality for all delicate preparations such as fish mousse, fine stuffing, vegetable terrine, foie gras block terrine, ganache, etc.

The advantages of vacuum processing:

- Better preservation
- Better presentation
- Better development of aromas and flavours
- Better cooking



**BOOST
PRODUCTIVITY**

R 30

12 kg = 4 min

Hummus



FLOOR STANDING VERTICAL CUTTER MIXERS



Quantities*



4 to 17 kg



6 to 36 kg

2 SPEEDS 1 500 and 3 000 rpm

R 30



OPTIONAL
3
BLADES

28 L

• Three phase

R 60



OPTIONAL
3
BLADES

60 L

• Three phase

*Quantities processed at the same time

PERFORMANCE RATES

Models	Maximum capacity				Number of covers	Time
	Coarse chopping (up to)	Emulsions (up to)	Pastry/dough* (up to)	Grinding (up to)		
R 30	12 kg	17 kg	14 kg	14 kg	600 to 1200	1 to 4 minutes
R 60	25 kg	36 kg	30 kg	30 kg	1200+	

*Amount of raised dough with 60% hydration



Find all our table-top models on page 68



R 30

Motor	Induction
Power	5 400 W
Voltage	Three phase
Speed	1 500 rpm - 3 000 rpm
Pulse	✓
IP85 control panel with digital timer	✓
Bowl	28 L stainless steel
Lid wiper	✓
Blade	All stainless steel detachable, adjustable 3 smooth blade assembly - Included
3 retractable wheels	✓

Choose your model:



R 30	Ref.
R 30 400V/50/3	52331C



R 60

Motor	Induction
Power	11 000 W
Voltage	Three phase
Speed	1 500 rpm - 3 000 rpm
Pulse	✓
IP85 control panel with digital timer	✓
Bowl	60 L stainless steel
Lid wiper	✓
Blade	All stainless steel detachable, adjustable 3 smooth blade assembly - Included
3 retractable wheels	✓

R 60	Ref.
R 60 400V/50/3	54331C

Choose your options:

Options	R 30	R 60
	Ref.	Ref.
Stainless steel coarse serrated 3 blade assembly Especially for grinding & kneading	57075	57092
Stainless steel fine serrated 3 blade assembly Especially for herbs & spices	57077	57095
Additional stainless steel smooth 3 blade assembly	57074	57091
Coarse serrated blade	118286S	118290S
Fine serrated blade	118241S	118245S
Smooth blade	117950S	117954S
3-height GN1x1 adjustable trolley	49128	49128

Robot Cook®

COOKING CUTTER BLENDER





The 1st professional Cooking Cutter Blender!

The Robot Cook[®] emulsifies, grinds, mixes, chops, blends and kneads to perfection. The heating temperature is variable, up to 140°C, and is accurate to the nearest degree. The large capacity bowl means that large quantities can be produced when needed.



Robot Cook®

THE KITCHEN ASSISTANT FOR CHEFS

Clever: Watertight lid including a no-splash safety function. Anti-vapour lid wiper so you can keep an eye on your preparation.

Practical: The opening in the lid means ingredients can be added to the bowl without having to stop the appliance.



Ingenious: Special system to hold the blade in place so the bowl can be emptied safely.

Efficient: Bowl scraper arm for ultra-fine, homogeneous preparations.

Functional: Large capacity 3.7 litre bowl for producing professional quantities.

Powerful: The powerful Robot Cook® features on a heavy duty commercial grade induction motor.

Hygienic: All parts in contact with food can be easily removed and are dishwasher safe.

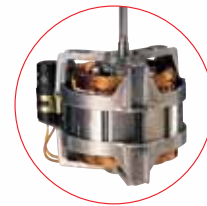

INDUCTION MOTOR

Easy Guide

High-precision: Variable heating capacity up to 140°C, accurate to the nearest degree.

Quiet: In the midst of the general hustle and bustle of the kitchen, Chefs appreciate how quiet it is.

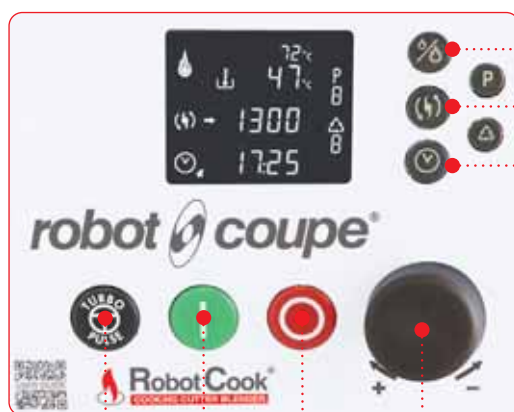

1 2 3
PROCESSING ZONE

Control dial
(to adjust settings)

SETTING ZONE

- Low and high heating capacity up to 140°C
- Variable speed from 500 to 3500 rpm
- Timer

PROGRAMMING ZONE

- P Programme
- △ Step button

PROCESSING ZONE

- 1 Turbo/pulse function: up to 4500 rpm
- 2 Start button
- 3 Stop button



BOOST PRODUCTIVITY

An autonomous assistant

Up to 140°C



Robot Cook® COOKING CUTTER BLENDER

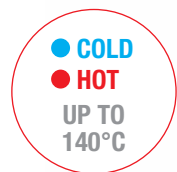

Robot Cook®

Motor	Induction
Power	1 800 W
Voltage	Single phase
Speed	<ul style="list-style-type: none"> • Variable speed from 100 to 3 500 rpm • High-speed turbo of 4 500 rpm • R-Mix blend speed 100 to 500 rpm • Intermittent slow speed blade rotation every 2 seconds
Heating temperature	Up to 140°
Pulse	✓
Bowl	3.7 L stainless steel
Scraper arm	✓
Wall mounted blade holder	✓

Blades Fine serrated blade for blender function
Included
 Smooth blade for cutter function - **Included**
 Blade cleaning tool - **Included**

Choose your model:



ROBOT COOK®	Ref.
Robot Cook® 230V/50/1 UK plug	43001R

Choose your options:

Options	Ref.
Additional bowl set (bowl + blade + lid + scraper)	39854
Additional fine serrated blade for blender function	39691
Additional smooth blade for cutter function	49691

●● EMULSIFY



●● CHOP



●● BLEND



●● GRIND



●● MIX



●● KNEAD



Blixer®



THE SOLUTION FOR TEXTURE MODIFIED FOOD

The Blixer[®], especially designed for the healthcare sector, turns raw products into texture modified foods.

All foods, whether raw or cooked, sweet or savoury, whether entrees or mains, dessert or cheese, can be eaten by everyone at the table.



TABLE-TOP Blixer®

INNOVATION

Blixer® ARM
For a more even **consistency**.
Easy to remove and clean for **perfect hygiene**.



OPENING

So that liquids and solid ingredients can be added **during use**.

LID

Equipped with a seal for **perfect watertightness**.

HIGH BOWL SHAFT

High bowl shaft to process **large liquid quantities**.

INDUCTION MOTOR

Very powerful, to withstand intensive use over a long period of time.

Easy Guide



Fine serrated blade.

Standard speed of 3 000 rpm for **perfectly even consistency**.

INDUCTION MOTOR

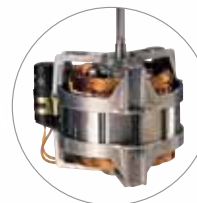

WHY HAVE A SECOND PROCESSING BOWL?

- Better organisation in the kitchen
- Reduces waiting time between 2 wash-ups

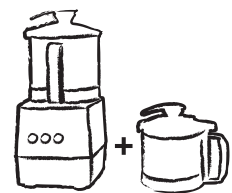

1 bowl for cold preparations



1 bowl for hot preparations





HEALTHCARE SECTOR - TEXTURE MODIFIED MEALS.....



DUO OF RAW RED CABBAGE AND CELERIAC

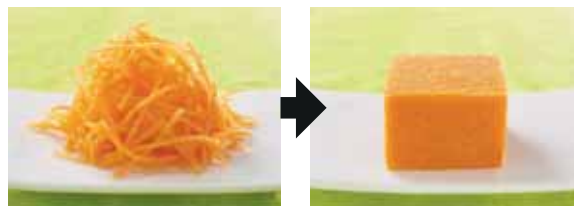

FRESHLY GRATED CARROTS



SALMON FILET AND CABBAGE



VEAL BLANQUETTE

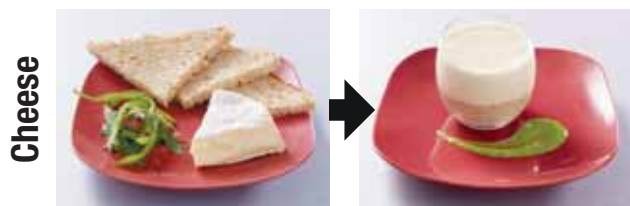

CAMEMBERT AND WHOLEMEAL BREAD



RAW GRANNY SMITH APPLE COMPOTE

HOW TO CHOOSE YOUR Blixer®

1 > Calculate the total weight of the texture-modified portions required.

	Average portion	Number of portions required	Total weight
Entree	80 g	X Portions = g
Meat / fish	100 g	X Portions = g
Vegetables / Carbs	200 g	X Portions = g
Dessert	80 g	X Portions = g

Number of 200 g portions

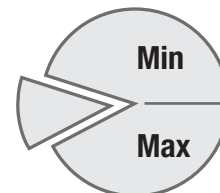

2 > Refer to the indications of the amounts processed per operation given in the product description.

RESTAURANTS - GASTRONOMY

It didn't take long for traditional and Asian food chefs to adopt the Blixer® for all their preparations:

Emulsions, appetizers, tapenade, hummus, taramasalata, pesto, etc.

Dry grinding, special "powders" for dry and dehydrated foods



**BOOST
PRODUCTIVITY**

Blixer® 7

4 kg = 90 sec

Texture-modified raw carrots

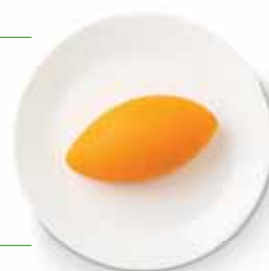
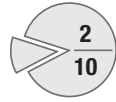
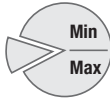

TABLE-TOP Blixer®

Number of
200 g
portions

Quantities
processed per
operation



0.3 to 2 kg

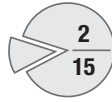

0.4 to 3 kg

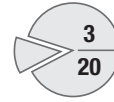

0.5 to 3.8 kg

VARIABLE SPEED from 300 to 3 500 rpm

Blixer® 4 V.V.

4.5 L



- Single phase

Blixer® 5 V.V.

5.9 L



- Single phase

2 SPEEDS 1 500 and 3 000 rpm

Blixer® 5 - 2V

5.9 L



- Three phase

1 SPEED 3 000 rpm

Blixer® 3

3.7 L



- Single phase

Blixer® 4 - 1V

4.5 L



- Single phase

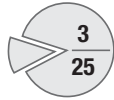

0.6 to 4.8 kg

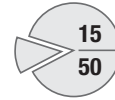

3 to 10 kg

VARIABLE SPEED from 300 to 3 500 rpm

Blixer® 7 V.V.

7.5 L



- Single phase

2 SPEEDS 1 500 and 3 000 rpm

Blixer® 15

15 L



- Three phase

PERFORMANCE RATES

Models	Quantities processed (kg)			Number of 200 g portions
	Bowl capacity (litres)	Min	Max	
Blixer® 3	3.7	0.3	2	2 to 10
Blixer® 4	4.5	0.4	3	2 to 15
Blixer® 5 - 5 V.V.	5.9	0.5	3.8	3 to 20
Blixer® 7 V.V.	7.5	0.6	4.8	3 to 25
Blixer® 15	15	3	10	15 to 50

TABLE-TOP Blixer®



Blixer® 3

Motor	Induction
Power	750 W
Voltage	Single phase
Speed	3 000 rpm
Pulse	✓
Motor base	Composite material
Bowl	3.7 L stainless steel
Watertight lid	✓
Blixer® arm	✓
Blade	Stainless steel fine serrated blade - Included Blade cleaning tool - Included
Number of 200 g portions	2-10

Blixer® 4 - 1V

Motor	Induction
Power	900 W
Voltage	Single phase
Speed	3 000 rpm
Pulse	✓
Motor base	Metal
Bowl	4.5 L stainless steel
Watertight lid	✓
Blixer® arm	✓
Blade	Stainless steel fine serrated blade - Included Blade cleaning tool - Included
Number of 200 g portions	2-15

Blixer® 4 V.V.

Motor	Induction
Power	1 100 W
Voltage	Single phase
Speed	300 to 3 500 rpm
Pulse	✓
Motor base	Metal
Bowl	4.5 L stainless steel
Watertight lid	✓
Blixer® arm	✓
Blade	Stainless steel fine serrated blade - Included Blade cleaning tool - Included
Number of 200 g portions	2-15

Choose your model:



Blixer® 3	Ref.
Blixer® 3 230V/50/1 UK plug	33198

Blixer® 4 - 1V	Ref.
Blixer® 4-1V 230V/50/1 UK plug	33209M

Blixer® 4 V.V.	Ref.
Blixer® 4 V.V. 230V/50-60/1 UK plug	33281M

Choose your options:

Options	Blixer® 3		Blixer® 4 all models	
	Ref.		Ref.	
Complete Blixer® bowl, blade, lid and scraper	27337		27338	
Additional fine serrated blade	27447		27449	
Coarse serrated blade	27448		27450	



Blixer® 5 - 2V

Motor	Induction
Power	1 500 W
Voltage	Three phase
Speed	1 500 rpm - 3 000 rpm
Timer	✓
Pulse	✓
Motor base	Metal
Bowl	5.9 L stainless steel
Watertight lid	✓
Blixer® arm	✓
Blade	Stainless steel fine serrated blade - Included Blade cleaning tool - Included
Number of 200 g portions	3-20

Choose your model:



Blixer® 5 - 2V	Ref.
Blixer® 5 2-V 400V/50/3	33259M



Blixer® 5 V.V.

Motor	Induction
Power	1 500 W
Voltage	Single phase
Speed	300 to 3 500 rpm
Timer	✓
Pulse	✓
Motor base	Metal
Bowl	5.9 L stainless steel
Watertight lid	✓
Blixer® arm	✓
Blade	Stainless steel fine serrated blade - Included Blade cleaning tool - Included
Number of 200 g portions	3-20

Blixer® 5 V.V.	Ref.
Blixer® 5 V.V. 230V/50-60/1 UK plug	33265M

Choose your options:

Blixer® 5 all models		
Options	Ref.	
Complete Blixer® bowl, blade, lid and scraper	27322	
Additional fine serrated blade	27310	
Coarse serrated blade	27311	
Blade cleaning tool	49258	

TABLE-TOP Blixer®



Blixer® 7 V.V.

Motor	Induction
Power	1 500 W
Voltage	Single phase
Speed	300 to 3 500 rpm
Timer	✓
Pulse	✓
Motor base	Metal
Bowl	7.5 L stainless steel
Watertight lid	✓
Blixer® arm	✓
Blade	Stainless steel fine serrated blade - Included Blade cleaning tool - Included
Number of 200 g portions	3-25

Choose your model:



Blixer® 7 V.V.	Ref.
Blixer® 7 V.V. 230V/50-60/1 UK plug	33298M

Choose your options:

Blixer® 7 V.V.	
Options	Ref.
Complete Blixer® bowl, blade, lid and scraper	27323
Additional composite blade assembly with stainless steel fine-serrated blades	27316
Additional composite blade assembly with stainless steel coarse-serrated blades	27317
Additional stainless steel fine serrated 2 blade assembly	27313
Additional stainless steel coarse serrated 2 blade assembly - Especially for grinding	27314
Additional lower fine-serrated blade	49166
Additional upper fine-serrated blade	49167
Additional lower coarse-serrated blade	49168
Additional upper coarse-serrated blade	49169
Blade cleaning tool	49258



Blixer® 15

Motor	Induction
Power	3 000 W
Voltage	Three phase
Speed	1 500 rpm - 3 000 rpm
Pulse	✓
Bowl	15 L stainless steel
See-through watertight lid	✓
Removable Blixer® arm	✓
Blade	All stainless steel detachable adjustable fine serrated 3 blade assembly - Included
Number of 200 g portions	15-50

Choose your model:



Blixer® 15	Ref.
Blixer® 15 400V/50/3	51511

Choose your options:

Blixer® 15	
Options	Ref.
Complete Blixer® bowl, blade, lid and scraper	57065
Fine serrated 3 blade assembly	57102
Additional fine serrated blade	59359



IMMERSION BLENDERS



OPTIMUM RESULTS, NO MATTER THE QUANTITY...

...no matter the receptacle, no matter the intended use, Robot-Coupe Immersion Blenders will meet all your needs!

They can mix, blend, emulsify, whip or knead your preparations in no time!

Their performance in terms of hygiene, ease of use, versatility and durability makes them the best on the market.



IMMERSION BLENDERS

ERGONOMICS

Ergonomic handle for greater convenience.

PERFORMANCE

High-power motor and increased performance to **optimise blending time**.

Easy Guide

LONG SERVICE LIFE

Stainless steel motor base for intensive use.

INNOVATION

CLEANING

Removable stainless steel bell and blade for easy cleaning and maintenance. Patented Robot-Coupe system.



STAINLESS STEEL BELL



The MP V.V. and MP Combi models feature an **ergonomic variable speed button** for greater user comfort.

INNOVATION



ERGONOMICS

The **lug on the motor base** can be used to rest the mixer on the rim of the pan to make it easier to handle and relieve some of the strain.

New cord winding system to make it easier to store and prevent wear and tear.

NEW



New EasyGrip removable handle. The machine's weight is distributed better making it even easier to use!

AFTER SALES SERVICE: DETACHABLE POWER CORD

- The patented "EasyPlug" system** means that the power cord can be easily replaced during after-sales servicing.
- Indicator light:** quick detection of power cord failure. The green light comes on if the cord is undamaged and correctly plugged in on both sides (wall socket and EasyPlug).





SOUPS



SAUCES



COULIS



EMULSIONS



The AeroMix tool is available on the Mini and MicroMix® product lines.



BOOST PRODUCTIVITY

MP 450 Ultra

100 L = 5 min

Soups

MP 800 Turbo

400 L = 6 min











Soups

DISCOVER OUR PAN SUPPORTS TO RELIEVE STRAIN

Page 104



IMMERSION BLENDERS

MINI			COMPACT			LARGE					
Mini MP See page 100			CMP See page 102			MP See page 105					
											
165 mm	190 mm	240 mm	250 mm	300 mm	350 mm	350 mm	450 mm	550 mm	600 mm	740 mm	
220 W MicroMix®	270 W Mini MP 190 V.V.	290 W Mini MP 240 V.V.	310 W CMP 250 V.V.	350 W CMP 300 V.V.	400 W CMP 350 V.V.	440 W MP 350 Ultra	500 W MP 450 Ultra	750 W MP 550 Ultra	850 W MP 600 Ultra	1000 W MP 800 Turbo	
			15 litres	30 litres	45 litres	50 litres	100 litres	200 litres	300 litres	400 litres	
For emulsions			For small preparations			For restaurants & cafés			For intensive use Institutions and caterers		

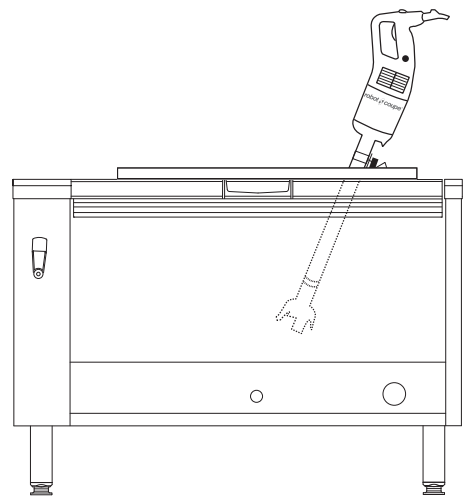
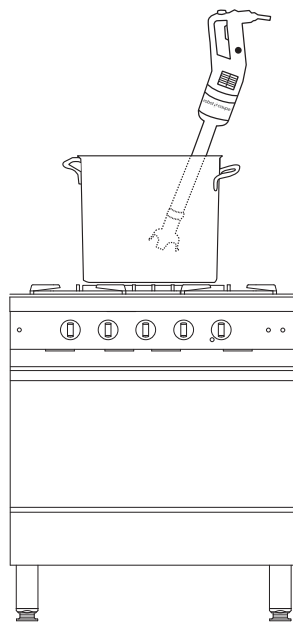
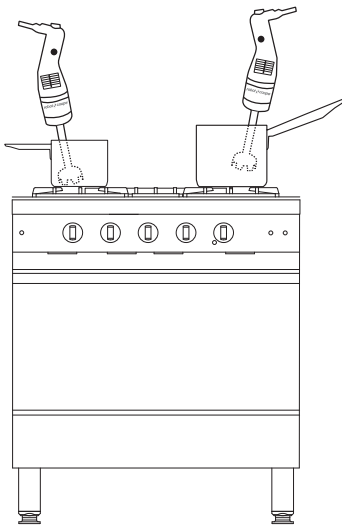

COMBI

MINI MP - CMP - MP Ultra

See page 108



290 W
Mini MP
240 Combi

For small
preparations



350 W
CMP 300
Combi

30 litres

For restaurants
& cafés



440 W
MP 350
Combi Ultra

50 litres

For intensive use
Institutions and caterers

CLEANING



Quick and easy to clean:

- 1 The stainless steel blade and bell are easy to remove.
- 2 Each machine comes with a disassembling tool.



To comply with the HACCP requirement, we advise users to store the bell and blade in a cool room after cleaning.

MICROMIX®

The top choice of chefs. Only a few seconds are needed to make a perfect emulsion!

PERFORMANCE

Bell design reduces blending time. **Powerful and quiet.**

HEAVY DUTY

All stainless steel tube, bell, motor housing and tools.

ERGONOMICS

High precision, easy to access variable speed button. Extendable coiled power cord for easier handling. Maximum length 1300 mm. Ideal for use just before serving.



CLEANING

The tube and attachments can be removed for easy cleaning. Practical storage for the immersion blender and attachments.



INNOVATION

AEROMIX

Patented tool designed to make instant light fluffy **emulsions** that always keep their shape on the plate.



BLADE

For making **small portions** of all your favourite **soups and sauces**.



ONLY A FEW SECONDS ARE NEEDED TO MAKE A PERFECT EMULSION!





Wall support



MicroMix®

Power	220 W
Voltage	Single phase
Speed	1 500 to 14 000 rpm
Blade and shaft	Length 165 mm - all stainless steel
Removable blade	✓
Removable foot	✓
Dimensions	Length 430 mm, Ø 61 mm
Gross weight	1.4 kg
Accessories	Stainless steel Aeromix - Included Wall support - Included



Special Merchandising Pack
to display 6 MicroMix® mixers in showrooms.

	Ref.	Sales unit	Packaging unit	
MicroMix 230V/50/1 UK plug	34901	1	1	
Pack of 6 MicroMix	34951	1	6	

BACK TO SUMMARY

MINI PRODUCT RANGE

Minimum size, maximum performance!

For sauces, emulsions and small preparations.



VARIABLE SPEED BUTTON
Easy to see and adjust.

HANDLE DESIGN
for easy grip and **effortless use.**



Detachable stainless steel blade and shaft for perfect hygiene.

 **Easy Guide**



Blade designed for optimum blending.

STAINLESS STEEL BELL

STAINLESS STEEL MOTOR HOUSING
To make the immersion blender last longer.

INNOVATION

AEROMIX

Patented emulsifying tool designed to make instant light fluffy **emulsions** that always keep their shape on the plate.



BLADE



AEROMIX For emulsions





Mini MP 190 V.V.

Power	270 W
Voltage	Single phase
Speed	2 000 to 12 500 rpm
Blade, bell and shaft	Length 190 mm - all stainless steel
Removable blade	✓
Removable bell	✓
Removable foot	✓
Dimensions	Length 485 mm, Ø 78 mm
Gross weight	2.5 kg
Accessories	Stainless steel Aeromix - Included Wall support - Included

Mini MP 240 V.V.

Power	290 W
Voltage	Single phase
Speed	2 000 to 12 500 rpm
Blade, bell and shaft	Length 240 mm - all stainless steel
Removable blade	✓
Removable bell	✓
Removable foot	✓
Dimensions	Length 535 mm, Ø 78 mm
Gross weight	2.5 kg
Accessories	Stainless steel Aeromix - Included Wall support - Included

Choose your model:



Mini MP 190 V.V.	Ref.
Mini MP 190 V.V. 230V/50/1 UK plug	34751

Mini MP 240 V.V.	Ref.
Mini MP 240 V.V. 230V/50/1 UK plug	34761



Whisk function

Mini MP 240 Combi

See page 107

CMP COMPACT PRODUCT RANGE

Compact, easy-to-handle, high-performance.
For restaurants & cafés



PERFORMANCE

Optimum blending for a fine textured end product in a minimum amount of time.



LONG SERVICE LIFE

Stainless steel motor base for intensive use.

DURABILITY

Equipped with a 3-level watertightness system.

INNOVATION



CLEANING

Removable stainless steel bell and blade for easy cleaning and maintenance.



POWERFUL

High-Power motor: +15 % for greater efficiency.

COMFORT

Variable speed for greater flexibility when making sophisticated preparations.

INNOVATION



ERGONOMICS

Light, compact, easy-to-handle appliance.

The lug on the motor base can be used to rest the mixer on the rim of a pan to make it easier to handle and remove some of the strain.

New cord winder to make it easier to store and prevent wear and tear.

AFTER SALES SERVICE: DETACHABLE POWER CORD

- 1 The new patented "EasyPlug" system means that the power cord can be easily replaced during after-sales servicing.
- 2 **Indicator light:** rapid detection of power cord failure. The green light comes on if the cord is undamaged and correctly plugged in on both sides (wall socket and EasyPlug).





CMP 250 V.V.

Power	310 W
Voltage	Single phase
Speed	2 300 to 9 600 rpm (self regulating system)
Blade, bell and shaft	Length 250 mm - all stainless steel
Removable blade	✓
Removable bell	✓
Removable foot	No
Dimensions	Length 650 mm, Ø 94 mm
Gross weight	3.9 kg
Accessories	Wall support - Included

CMP 300 V.V.

Power	350 W
Voltage	Single phase
Speed	2 300 to 9 600 rpm (self regulating system)
Blade, bell and shaft	Length 300 mm - all stainless steel
Removable blade	✓
Removable bell	✓
Removable foot	No
Dimensions	Length 660 mm, Ø 94 mm
Gross weight	3.9 kg
Accessories	Wall support - Included

CMP 350 V.V.

Power	400 W
Voltage	Single phase
Speed	2 300 to 9 600 rpm (self regulating system)
Blade, bell and shaft	Length 350 mm - all stainless steel
Removable blade	✓
Removable bell	✓
Removable foot	No
Dimensions	Length 700 mm, Ø 94 mm
Gross weight	4.1 kg
Accessories	Wall support - Included

Choose
your model:



CMP 250 V.V.	Ref.
CMP 250 V.V. 230V/50/1 UK plug	34241B

CMP 300 V.V.	Ref.
CMP 300 V.V. 230V/50/1 UK plug	34231B

CMP 350 V.V.	Ref.
CMP 350 V.V. 230V/50/1 UK plug	34251B



Whisk function
CMP 300 Combi
See page 109

MP/CMP PAN SUPPORTS

Pan supports reduce MSD risks, relieve strain and make it easier to control preparations.

They enable the immersion blender to be tilted effortlessly or left to do the job by itself.

Made entirely of stainless steel, they can be removed completely, are easy to clean and practical to use.

1 Universal pan support: Fits all pan sizes.



2 Adjustable pan supports:

Three pan supports are available as an option. They adapt to the size of the pan:

- pan Ø from 330 mm to 650 mm.
- pan Ø from 500 mm to 1 000 mm.
- pan Ø from 850 mm to 1 300 mm.



Stainless steel pan supports

1 universal stainless steel pan support 1	Ref.
To be attached to the edge of the pan.	27358
3 adjustable stainless steel pan supports 2	Ref.
For 330 to 650 mm diameter pans	27363
For 500 to 1000 mm diameter pans	27364
For 850 to 1300 mm diameter pans	27365

MP ULTRA LARGE PRODUCT RANGE

Even better performance and ergonomics!

ERGONOMICS

Ergonomic handle for greater user comfort.

PERFORMANCE

High-power motor and increased performance to **optimise blending time**.

Easy Guide

LONG SERVICE LIFE

Stainless steel motor base for intensive use.

INNOVATION

CLEANING

Removable stainless steel bell and blade for easy cleaning and maintenance. Patented Robot-Coupe system.



The MP V.V. and MP Combi models feature an **ergonomic variable speed button** for greater user comfort.

INNOVATION



ERGONOMICS

The lug on the motor base can be used to rest the mixer on the rim of the pan to make it easier to handle and relieve some of the strain.

New cord winding system to make it easier to store and prevent wear and tear.

NEW



New EasyGrip removable handle. The machine's weight is distributed better making it even easier to use!

AFTER SALES SERVICE: DETACHABLE POWER CORD

- The patented "EasyPlug" system** means that the power cord can be easily replaced during after-sales servicing.
- Indicator light:** quick detection of power cord failure. The green light comes on if the cord is undamaged and correctly plugged in on both sides (wall socket and EasyPlug).





MP 350 Ultra

Power	440 W
Voltage	Single phase
Speed	9 500 rpm
Blade, bell and shaft	Length 350 mm - all stainless steel
Removable blade	✓
Removable bell	✓
Removable foot	No
EasyPlug	✓
Dimensions	Length 740 mm, Ø 125 mm
Gross weight	6.2 kg
Accessories	Wall support - Included



MP 450 Ultra

Power	500 W
Voltage	Single phase
Speed	9 500 rpm
Blade, bell and shaft	Length 450 mm - all stainless steel
Removable blade	✓
Removable bell	✓
Removable foot	No
EasyPlug	✓
Dimensions	Length 840 mm, Ø 125 mm
Gross weight	6.3 kg
Accessories	Wall support - Included

Choose your model:



MP 350 Ultra	Ref.
MP 350 Ultra 230V/50/1 UK plug	34801L

MP 450 Ultra	Ref.
MP 450 Ultra 230V/50/1 UK plug	34811L



Whisk function
MP 350 Combi Ultra
 See page 109

Choose your options:

MP 350 Ultra / MP 450 Ultra		
Options	Ref.	
EasyGrip removable handle	27359	



MP 550 Ultra

Power	750 W
Voltage	Single phase
Speed	9 000 rpm
Blade, bell and shaft	Length 550 mm - all stainless steel
Removable blade	✓
Removable bell	✓
Removable foot	No
Second handle	Removable EasyGrip handle
Electronic booster system	No
EasyPlug	✓
Dimensions	Length 940 mm, Ø 125 mm
Gross weight	6.6 kg
Accessories	Wall support - Included



MP 600 Ultra

Power	850 W
Voltage	Single phase
Speed	9 500 rpm
Blade, bell and shaft	Length 600 mm - all stainless steel
Removable blade	✓
Removable bell	✓
Removable foot	No
Second handle	Removable EasyGrip handle
Electronic booster system	No
EasyPlug	✓
Dimensions	Length 980 mm, Ø 125 mm
Gross weight	7.4 kg
Accessories	Wall support - Included



MP 800 Turbo

Power	1 000 W
Voltage	Single phase
Speed	9 500 rpm
Blade, bell and shaft	Length 740 mm - all stainless steel
Removable blade	✓
Removable bell	✓
Removable foot	✓
Second handle	Integrated stainless steel handle
Electronic booster system	✓
EasyPlug	✓
Dimensions	Length 1 130 mm, Ø 125 mm
Gross weight	9.2 kg
Accessories	Wall support - Included

Choose your model:



MP 550 Ultra	Ref.
MP 550 Ultra 230V/50/1 UK plug	34821LH

MP 600 Ultra	Ref.
MP 600 Ultra 230V/50/1	34831LH

MP 800 Turbo	Ref.
MP 800 Turbo 230V/50/1	34891L

IMMERSION BLENDERS

COMBI PRODUCT RANGE

The Robot-Coupe whisk attachment available for Mini MP Combi, CMP Combi, MP Combi Ultra and MP FW mixers is designed to emulsify, mix, shell, beat and knead.

POWERFUL

High-strength motor:

+15 % for greater efficiency.

EASY TO OPERATE

Variable speed button easy to use with one hand.

ERGONOMIC

Ergonomic handle for easier grasping.

CONVENIENT

Self regulating speed system for sophisticated preparations.



EMULSIFY



Salad dressing, mayonnaise, sauces, etc.

MIX



Pancake batter, tomato pulp, seasoning, etc.

SHELL



Semolina, rice, wheat, quinoa, etc.

BEAT



Egg whites, chocolate mousse, whipped cream, etc.

KNEAD/MASH



Mashed potatoes, doughnut dough, batter, etc.

INNOVATION



METAL WHISK BOX

HEAVY DUTY

Metal gears inside 2 metal housings to stand up to heavy duty use.

CLEANING

Overmoulded whisks to ensure perfect hygiene.

ERGONOMIC

Fast coupling of whisks to the gearbox and the gearbox to the motor housing for easy assembly and disassembly.



Mini MP 240 Combi

CMP 300 Combi

MP 350 Combi Ultra

Power	290 W	350 W	440 W
Voltage	Single phase	Single phase	Single phase
Speed	2 000 to 12 500 rpm for mixer function, 350 to 1 560 rpm for whisk function	2 300 to 9 600 rpm for mixer function, 500 to 1 800 rpm for whisk function with self regulating speed system	1 500 to 9 000 rpm for mixer, 250 to 1 500 rpm for whisk with self regulating speed system
Blade, bell and shaft	Length 240 mm all stainless steel	Length 300 mm all stainless steel	Length 350 mm all stainless steel
Removable blade	✓	✓	✓
Removable bell	✓	✓	✓
Removable foot	✓	✓ equipped with a 3-level watertightness system	✓
Metal whisk kit	✓	✓	✓
Detachable whisk	✓	✓	✓
EasyPlug	-	✓	✓
Dimensions	Total length with tube 535 mm with whisk 550 mm, Ø 78 mm	Total length with tube 700 mm with whisk 610 mm, Ø 125 mm	Total length with tube 790 mm with whisk: 805 mm, Ø 125 mm
Gross weight	2.8 kg	5.7 kg	7.9 kg
Accessories	Stainless steel Aeromix Included Wall support - Included	Wall support - Included	Wall support - Included

Choose your model:



Mini MP 240 Combi	Ref.
Mini MP 240 Combi 230V/50/1 UK plug	34781

CMP 300 Combi	Ref.
CMP 300 Combi 230V/50/1 UK plug	34311B

MP 350 Combi Ultra	Ref.
MP 350 Combi Ultra 230V/50/1 UK plug	34861L

Choose your options:

	Mini MP 240 Combi		CMP 300 Combi		MP 350 Combi Ultra	
Options	Ref.		Ref.		Ref.	
Whisk attachment	27333		27248		27210	
Mixing attachment	-	-	-	-	27355	
Mixer foot	-	-	27250		39354	
EasyGrip removable handle	-	-	-	-	27359	

[BACK TO SUMMARY](#)

JUICE EXTRACTORS



ULTRA FRESH FRUIT JUICE IN JUST A FEW SECONDS!

Robot Coupe juice extractors partner professionals in a wide variety of sectors: bars, restaurants, hotels, institutions and supermarkets.

Quick, efficient and heavy duty with a fast ROI, they provide the ideal solution for making large quantities of ultra fresh fruit and vegetable juices.



JUICE EXTRACTORS

INNOVATION

Ø 79 mm **FEED-HEAD**
For whole fruit
and vegetables.



AUTOMATIC FEED TUBE

- With the exclusive automatic feed system, fruit and vegetables are processed effortlessly.
- Fast: 25 cl in just 6 seconds.



BASKET

Two handles for a better grip, can be removed without tools and is easy to clean.



INDUCTION MOTOR

Easy Guide

NEW

Anti-splash spouts in 2 different sizes*:

- 1 Jug / Blender bowl
- 2 Served by the glass



NEW

DRIP TRAY*

Large capacity so the worktop is always clean.



NEW

INCLINED BASE*

For optimum evacuation of juice.

MOTOR

- Quiet so it can be used right in front of the customer.
- 1000 W designed for intensive use throughout the day*



Pulp is ejected under the worktop*

Two ways of using the juicer:



- 1 **Pulp ejected into a container.**
Large capacity translucent pulp collector.

- 2 **Continuous pulp ejection*.**
Pulp ejection chute: continuous pulp ejection directly into a bin under the worktop.



*J 100 only

OUR USERS



BARS, RESTAURANTS AND HEALTHCARE FACILITIES

Fresh fruit and vegetable juices are a way of adding a touch of freshness to bar and restaurant menus. They are also highly appreciated in hospitals and retirement homes to prevent residents from being dehydrated.



HOTELS, CANTEENS AND CAFETERIAS

Quiet and easy to operate, Robot-Coupe Juice Extractors provide self-service in hotel breakfast bars and school canteens.



JUICE BARS AND SUPERMARKETS

Especially designed for intensive use, our Juice Extractor range is perfect for the production of large quantities.



**BOOST
PRODUCTIVITY**

2 L = 1 min

Fresh juice



**RETURN
ON INVESTMENT**



20 glasses /
day

=

**J 100 written
off in 25 days**



ZERO WASTE

100% sustainable profitability



Add your vegetable or fruit pulp to the batter for your cakes, waffles, salads, and even your omelettes.



Scan the QR code for zero-waste recipes!

JUICE EXTRACTORS

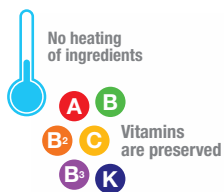

J 80

Motor	Induction
Power	700 W
Voltage	Single phase
Flow rate	120 L/h
Bowl	Stainless steel
Feed Hopper	✓ - Automatic Ø 79 mm
Filter	Stainless steel
Grating disc	Stainless steel
Useful height under spout	155 mm
TYPE OF SERVICE: Glass	✓
Jug	✓
Blender bowl	-
No-splash spout	✓ - 1 size
Inclined base	-
Drip catcher tray	✓
Automatic pulp ejection	✓
Translucent pulp collector	6.5 L
Continuous pulp ejection chute	-

Choose your model:



J 80	Ref.
J 80 230V/50/1 UK plug	56001B

Choose your options:

J 80	
Option	Ref.
Inclined base assembly	49230

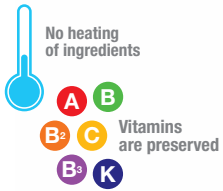

J 100

Motor	Induction
Power	1 000 W
Voltage	Single phase
Flow rate	160 L/h
Bowl	Stainless steel
Chute	✓ - Automatic Ø 79 mm
Filter	Stainless steel
Grating disc	Stainless steel - For intensive use
Useful height under spout	251 mm
TYPE OF SERVICE: Glass	✓
Jug	✓
Blender bowl	✓
No-splash spout	✓ - 2 sizes
Inclined base	✓
Drip catcher tray	✓ - Large capacity
Automatic pulp ejection	✓
Translucent pulp collector	7.2 L
Continuous pulp ejection chute	✓

Choose your model:

J 100	Ref.
J 100 230V/50/1 UK plug	56101B



Choose your options:

J 100	
Option	Ref.
Inclined base assembly	49230



PLANETARY MIXER



UNMATCHED RESULTS. UNMATCHED ERGONOMICS.

Robot-Coupe Planetary Mixers are the ideal day-to-day tool for kitchen chefs and pastry chefs.



PLANETARY MIXER

NEW

Ultra-quiet and extremely convenient to use.

PERFORMANCE

Attachments designed to perfectly match the bowl's shape.

The bowl is very curved which makes kneading easy and allows very small quantities to be produced.

PRODUCTIVITY

Large-capacity stainless steel bowl.
Ergonomic handle.

HEAVY DUTY

all-metal frame for perfect stability and easy maintenance.

ERGONOMICS

Tilttable head for total release of attachments and easy insertion of bowl. Robot-Coupe patented bowl lock-in system.

Easy Guide

POWERFUL

Commercial-grade motor stands up to intensive use.



STAINLESS STEEL ACCESSORIES



STAINLESS STEEL WHISK

For producing very light fluffy whipped cream. **1 L of pure cream produces 3 L of whipped cream.**



STAINLESS STEEL PADDLE

Because the paddle keeps bringing the preparation back to the middle of the bowl, the mixture has a very even consistency. **Up to 1.5 kg of softened butter in a minimum amount of time.**



STAINLESS STEEL SPIRAL HOOK

Optimum kneading of bread dough with the **patented kneading hook**. **Up to 4 kg of bread dough (63% d'hydration).**

SAFETY

Meets the EN 454 professional safety standard with:

- > Safety shield preventing access to the attachment
- > Lock-in system
- > Bowl detection device

NEW



RM 8

Motor	Induction
Power	700 W
Voltage	Single phase
Speed	10 speeds from 60 to 600 rpm
Bowl	7.6 L stainless steel with handle

Attachments Stainless steel whisk, paddle, spiral hook
Included

Choose your model:



RM 8	Ref.
RM 8 220-240V/50-60/1 UK	26231D

Choose your options:

RM 8	
Options	Ref.
7.6 L stainless steel bowl with handle	28419
Whisk	28439
Paddle	28438
Spiral kneading hook	28437
7.6L bowl and 3 accessories assembly	28440



**BOOST
PRODUTIVITY**



Whisk

**2 to 16
egg whites**



Paddle

**up to 1,5 kg
softened butter**



**Spiral
hook**

**up to 4 kg
bread dough***



*(63% hydration)

[BACK TO SUMMARY](#)

2026 Edition *robot coupe*® 119

TECHNICAL DATA

FOOD PROCESSORS					Dimensions (mm)						Weight (kg)	
Description	Ref.	Power (w)	Single phase	Three phase	Machine			Packaging			Net	Gross
					L	D	H	L	D	H		
R 301 Ultra 230V/50/1	2447	650	•		355	305	570	610	410	570	14	17
R 402 V.V. 230V/50/1	2478	1 000	•		320	305	590	610	410	570	22	23
R 502 V.V. 230V/50-60/1	2389	1 500	•		380	365	670	490	390	650	30	35
R 752 V.V. 230V/50-60/1	2080	1 500	•	•	380	365	710	490	390	650	34	38

VEGETABLE PREPARATION MACHINES					Dimensions (mm)						Weight (kg)	
Description	Ref.	Power (w)	Single phase	Three phase	Machine			Packaging			Net	Gross
					L	D	H	L	D	H		
CL 50 Ultra 230V/50/1	24470	550	•		380	305	595	400	390	640	18	20
CL 52 230V/50/1	24492	750	•		360	340	690	400	390	800	26	28
CL 55 2 Feed Head 230V/50/1	2073	1 100	•		865	396	1270	1120	785	510	42	61
CL 55 2 Feed Head 400V/50/3	2211	1 100		•	865	396	1270	1120	785	510	42	61
CL 60 2 Feed Head 400V/50/3	2325FA	1 500		•	460	770	1355	1120	800	900	69	95

CUTTER MIXERS					Dimensions (mm)						Weight (kg)	
Description	Ref.	Power (w)	Single phase	Three phase	Machine			Packaging			Net	Gross
					L	D	H	L	D	H		
R 2 230V/50/1	22107D	550	•		245	305	380	400	300	540	9	11
R 3 3000 230V/50/1	22389	650	•		210	320	400	400	300	540	12	13
R 4 V.V. 230V/50-60/1	22412	1 000	•		225	305	460	400	300	540	17	18
R 5 V.V. 230V/50-60/1	24623M	1 500	•		280	365	510	490	390	650	22	24
R 7 V.V. 230V/50-60/1	24711M	1 500	•		280	365	540	490	390	650	23	26
R 8 400V/50/3	21291	2 200		•	315	545	585	700	470	700	37	45

Robot Cook®					Dimensions (mm)						Weight (kg)	
Description	Ref.	Power (w)	Single phase	Three phase	Machine			Packaging			Net	Gross
					L	D	H	L	D	H		
Robot Cook 230V/50-60/1	43001R	1 800	•		225	340	520	410	310	590	14	16

Blixer®					Dimensions (mm)						Weight (kg)	
Description	Ref.	Power (w)	Single phase	Three phase	Machine			Packaging			Net	Gross
					L	D	H	L	D	H		
Blixer® 3 230V/50/1	33198	750	•		245	305	460	390	295	560	12	14
Blixer® 4 230V/50/1	33209	900	•		240	330	480	400	300	540	14	15
Blixer® 4 V.V. 230V/50-60/1	33281	1 100	•		240	330	480	400	300	540	16	17
Blixer® 5 - 2V 400V/50/3	33259M	1 500		•	280	365	540	490	390	650	21	24
Blixer® 5 V.V. 230V/50-60/1	33265M	1 500	•		280	365	540	490	390	650	22	24
Blixer® 7 V.V. 230V/50-60/1	33298M	1 500	•		280	365	570	490	390	650	23	25
Blixer® 15 400V/50/3	51511	3 000		•	315	545	700	765	465	780	50	59

IMMERSION BLENDERS					Dimensions (mm)					Weight (kg)	
Description	Ref.	Power (w)	Single phase	Three phase	Machine		Packaging			Net	Gross
					Ø	H	L	D	H		
MicroMix 230V/50/1	34901	220	•		61	430	435	155	75	1	1
Mini MP 190 V.V. 230V/50/1	34751	270	•		78	485	455	190	115	2	3
Mini MP 240 V.V. 230V/50/1	34761	290	•		78	535	455	190	115	2	3
CMP 250 V.V. 230V/50/1	34241B	310	•		94	650	690	230	130	3	4
CMP 300 V.V.230V/50/1	34231B	350	•		94	660	690	230	130	3	4
CMP 350 V.V. 230V/50/1	34251B	400	•		94	700	690	230	130	4	4
MP 350 Ultra 230V/50/1	34801L	440	•		125	740	930	275	155	5	7
MP 450 Ultra 230V/50/1	34811L	500	•		125	840	930	275	155	5	6
MP 550 Ultra 230V/50/1	34821LH	750	•		125	940	930	275	155	5	7
MP 600 Ultra 230V/50/1	34831LH	850	•		125	980	930	275	155	6	7
MP 800 Turbo 230V/50/1	34891L	1 000	•		125	1130	695	400	235	7	9
Mini MP 240 Combi 230V/50/1	34781	290	•		78	535	455	190	115	2	3
CMP 300 Combi 230V/50/1	34311B	350	•		125	700	560	345	130	3	6
MP 350 Combi Ultra 230V/50/1	34861L	440	•		125	790	930	275	155	6	8

JUICE EXTRACTORS					Dimensions (mm)						Weight (kg)	
Description	Ref.	Power (w)	Single phase	Three phase	Machine			Packaging			Net	Gross
					L	D	H	L	D	H		
J 80 230V/50/1	56001B	700	•		235	535	500	465	285	530	11	13
J 100 230V/50/1	56101B	1 000	•		260	565	630	790	292	530	15	18

PLANETARY MIXER					Dimensions (mm)						Weight (kg)	
Description	Ref.	Power (w)	Single phase	Three phase	Machine			Packaging			Net	Gross
					L	D	H	L	D	H		
RM 8 220-240V/50-60/1	26231D	700	•		320	513	405	540	335	475	17	21

TERMS AND CONDITIONS OF SALE RCC

1- INTERPRETATION

«Seller means Robot-Coupe Hong-Kong Limited.

«Conditions» means the standard terms and conditions of sale set out in this document and (unless the context otherwise requires) including any special terms and conditions agreed in writing between the Buyer and the Seller in accordance with clause 3.

«Contract» means the contract for the sale and purchase of the Equipment.

«Default» means any act, statement, omission, breach of obligation (whether expressed or implied, condition or warranty) contained in, precedent or collateral to the Contract, breach of duty under statute or at common law or negligence by or on the part of the Seller in connection with or arising out of the subject matter of the Contract.

«Equipment» means the goods including spare parts, purchased by the Buyer or to be serviced or repaired by the Seller.

2- GENERAL

It is acknowledged that all Equipment purchased under the Conditions are required by the Buyer in the course of his business.

3- BASIS OF THE SALE

The Seller shall sell and the Buyer shall purchase the Equipment in accordance with any written order of the Buyer which is accepted by the Seller subject to the Conditions which shall govern the Contract to the exclusion of any other terms and conditions subject to which any such order is made or purported to be made by the Buyer.

No binding Contract shall in any event arise until the Buyer's written order has been accepted by the Seller.

No variation of the Conditions shall be binding unless agreed in writing between the Seller and the Buyer.

Any samples, illustrations or descriptive material including but not limited to particulars of shade and pattern and other information contained in the Seller's brochures, advertising material or elsewhere shall not form part of the Contract and shall be treated as approximate and for guidance only unless specifically stated otherwise. The Seller may at its discretion from time to time vary the design of the Equipment from that advertised without notice to the Buyer provided that any such variations do not constitute material alterations to the Equipment.

4- PRODUCT WARRANTY

The terms of any specific product guarantee offered by the Seller to customers of the Equipment shall be specifically made part of the Conditions. The Buyer undertakes to observe the Seller's service policy as laid down from time to time.

The Seller warrants that the Equipment will correspond with its specification at the time of delivery and will be free from defects in material and workmanship for a period of 12 months from delivery.

The above warranty is given by the Seller subject to the following conditions:

the Seller shall be under no liability in respect of any defect arising from fair wear and tear, wilful damage, negligence, failure to follow the Seller's instructions (whether oral or in writing), misuse, alteration, or repair of the Equipment without the Seller's approval; and the Seller shall be under no liability under the above warranty (or any other warranty, condition or guarantee) if the defect is found to result from alteration or repairs made by the Buyer or on his authority without written consent of the Seller.

Warranty offered by the seller covers parts against any operating defects arising from manufacturing defects or defects in the material.

R and Blixer range from 20L to 60L and CL 55&60 range will have to be commissioned by Robot Coupe sales team for the warranty to be applied if the machines are used in, or close to the following cities:

Beijing - Shanghai - Shenzhen - Dongguan - Guangzhou - Hong Kong - Macau

5- CONDITIONS, WARRANTIES AND REPRESENTATIONS EXCLUDED

The Seller gives only those express warranties set out in condition 4 and no other conditions, warranties or representations (whether express or implied) are given, save as may be required to be given by law. In particular, but without prejudice to the generality of the foregoing, the implied conditions as to satisfactory quality shall be deemed to be satisfied after the expiration of twelve months and the only purpose for which the Equipment is supplied are laid down in the manual supplied with the Equipment.

In relation to any Default the Seller will accept unlimited liability for:

death or personal injury caused by the negligence of the Seller; and anything else for which the Seller cannot at law limit or exclude its liability.

The Seller will not be liable for the following loss or damage however caused/arising directly or indirectly out of any Default and even if foreseeable by the Seller:

economic loss including administrative and overhead costs, loss of profits, business, contracts, revenues, goodwill, production and anticipated savings of every description; loss arising from any claim made against the Buyer by any other person; or loss or damage arising from the Buyer's failure to fulfil its responsibilities or any matter under the control of the Buyer.

Except for the liabilities accepted by the Seller under sub-clause 5(b) the Seller's liability for any one Default shall be limited to an amount equal to the price of the Equipment.

6- DELIVERY

Risk of loss of or damage to any order of the Equipment shall pass to the Buyer at the time of delivery to the agreed place of delivery or if the Buyer wrongfully fails to take delivery of the Equipment, the time when the Seller has tendered delivery of the Equipment.

Dates of delivery are considered as approximate only unless there is a specific agreement to the contrary.

Where appropriate, shipping schedules shall be agreed between the parties, however the Equipment is sold subject to availability and the Seller shall be entitled to allocate for delivery to the Buyer smaller quantities of the Equipment than those ordered if in the Seller's sole opinion its supplies shall be insufficient to meet the requirements of all its customers.

7- PRICES AND CARRIAGE

Unless otherwise stated all prices for the Equipment shall be those in the Seller's current price list and, unless otherwise stated, shall be inclusive of all charges other than VAT or any other sales tax (which shall be payable by the Purchaser subject to receipt of a valid VAT invoice).

All orders shall be subject to a carriage charge, price upon application.

8- PAYMENT

Pre-payment is requested. Payment should be done through wire transfer to Robot Coupe bank account.

Orders of Cutter and Blixer range from 20L to 60L and Vegetable Preparation range from 55L to 60L will be accepted by seller once Robot-Coupe bank account has been credited of the full prepayment.

Goods will be released once Robot Coupe bank account has been credited of the payment.

9- CANCELLATION

No order which has been accepted by the Seller may be cancelled by the Buyer except with the agreement in writing of the Seller and on terms that the Buyer shall indemnify the Seller in full against all loss (including loss of profit) costs (including the costs of all labour and materials used) damages, charges and expenses incurred by the Seller as a result of cancellation.

10- RETENTION OF TITLE

The Seller and the Buyer expressly agree that until payment has been made in full for the Equipment:

-Property in any order of the Equipment shall not pass to the Buyer until the Seller has received in cash or cleared funds payment in full of the price of that order and all other Equipment supplied by the Seller to the Buyer for which payment is then due.

Until such time as the property in the Equipment passes to the Buyer, the Buyer shall:

hold the Equipment as the Seller's fiduciary agent and bailee; keep the Equipment separate from those of the Buyer and third parties and properly stored, protected, insured and identified as the Seller's property; and be entitled to resell or use the Equipment in the ordinary course of its business (unless the Seller revokes such entitlement in writing). On any such sale or use of the Equipment the Buyer shall sell or use those Equipment as have been longest in its possession.

Until such time as the property in the Equipment passes to the Buyer (and provided that the Equipment is still in existence and has not been resold) the Seller shall be entitled; at anytime to enter upon any premises where the Equipment is stored to inspect it; and at any time to require the Buyer to deliver up the Equipment to the Seller and, if the Buyer fails to do so forthwith, to enter upon any premises of the Buyer or any third party where the Equipment is stored and repossess the Equipment.

The Buyer shall not be entitled to pledge or in any way charge by way of security for any indebtedness any of the Equipment which remain the property of the Seller, but if the Buyer does so all monies owing by the Buyer to the Seller shall (without prejudice to any other right or remedy of the Seller) forthwith become due and payable.

The Buyer shall insure the Equipment with a reputable insurance company for its full market value and will provide such evidence of cover and payment of premium as the Seller may reasonably require. The Buyer further agrees to procure that the Seller is specified as loss payee in any such contract of insurance, if the Seller should so elect.

11- FORCE MAJEURE

The Seller shall not be liable to the Buyer or be deemed to be in breach of any Contract to which the Conditions apply by reason of any delay in performing, or any failure to perform, any of its obligations in relation to the Equipment, to the extent that the delay or failure was beyond the Seller's reasonable control.

If the Seller is prevented from fulfilling any order or Contract with a reasonable time by force majeure, it will notify the Buyer of the delay. The Seller shall be under no liability to the Buyer and shall be entitled to extend the time or times for delivery or otherwise performing such Contract for so long as such cause of prevention or delay shall continue.

If the event of force majeure continues for a period of more than 3 months, the Buyer shall have the right on giving notice to the Seller to terminate any Contract to which these Conditions apply.

12- INTELLECTUAL PROPERTY RIGHTS

The Equipment includes designs (the «Designs») which are the property of the Seller. The Buyer acknowledges that the Seller owns the copyright, design right and all other intellectual property rights in the Designs.

The Buyer agrees that the Designs may not be reproduced or used in any way except with the prior written consent of the Seller.

The Seller has not knowingly infringed any intellectual property rights of any third party but does not warrant or give any assurance to the Buyer that any Design does not infringe the intellectual property rights of any third party.

The Buyer shall leave in position and not cover, deface or erase any notices or other marks (including without limitation serial numbers and notices that a trade mark, design, patent or copyright relating to the Equipment is owned by the Seller or a third party) which the Seller may place on or affix to the Equipment.

The Buyer shall not in any of its stationery nor by any sign at its premises or otherwise indicate that it is in any way connected with the Seller other than that it is an appointed stockist of the Equipment.

13- GENERAL

The Buyer shall not without the prior written consent of the Seller sub-contract or assign the Contract to any other party.

Each clause and sub-clause in these Conditions is separate and severable and enforceable accordingly.



ROBOT COUPE HONG KONG LIMITED

樂伯特(香港)有限公司

7/F MEYER IND. BLDG., 2 CHONG YIP ST., KWUN TONG, KLN., HONG KONG

Tel. customer service : 2616 9328 / Tel. after-sales service : 2616 9878

Email : sales@robot-coupe.hk

www.robot-coupe.com

